



HOSE AND CORD REELS

| | Page |
|--|---------|
| Hose Reel Selection Guide | 216 |
| LD™ Series Enclosed Hose Reels | 218-220 |
| LDX™ Series Hose Reels | 221-222 |
| SDX™ Series Hose Reels | 223-228 |
| SD™ Series Cord and Light Reels | 229-232 |
| XDX™ Series 10/20 Hose Reels | 233-237 |
| XD™ Series 30 Hose Reels | 238-242 |
| XD™ Series 40/50 Hose Reels | 243-248 |
| XD™ Series 60/70/80 Powered Hose Reels | 250-259 |
| Hose Reel Accessories | 260-261 |

Graco Hose and Cord Reel Selection Guide

| | Typical Application | Typical Fluid | Hose/Cord Length Options | Enclosed | Reference Pages |
|---|---|--|--|----------|-----------------|
| LD™ Series  | <ul style="list-style-type: none"> • Small maintenance shops • Tire maintenance shops • Small fast lubes • Independent repair facilities • Industrial manufacturing facilities | <ul style="list-style-type: none"> • Petroleum- and synthetic-based oils • Air • Water • Grease • Antifreeze • Windshield washer fluid | <ul style="list-style-type: none"> • 35 ft (11 m) • 45 ft (14 m) • 50 ft (15 m) | Yes | 218-220 |
| LDX™ Series  | <ul style="list-style-type: none"> • Small maintenance shops • Tire maintenance shops • Small fast lubes • Independent repair facilities • Industrial manufacturing facilities | <ul style="list-style-type: none"> • Petroleum- and synthetic-based oils • Air • Water • Grease • Antifreeze • Windshield washer fluid • Diesel exhaust fluid (DEF) | <ul style="list-style-type: none"> • 45 ft (14 m) – DEF only • 50 ft (15 m) | No | 221-222 |
| SDX™ 10 / 20 Series  | <ul style="list-style-type: none"> • Car dealerships • Light-/medium-duty truck dealers • Fleet maintenance • Public works garages • Construction vehicle maintenance • Light-utility service trucks | <ul style="list-style-type: none"> • Petroleum- and synthetic-based oils • Air • Water • Grease • Antifreeze • Windshield washer fluid | <ul style="list-style-type: none"> • 35 ft (11 m) • 50 ft (15 m) • 65 ft (20 m) | Optional | 223-228 |
| SD™ Series Cord Reels  | <ul style="list-style-type: none"> • Automotive dealerships • Fast lube centers • Service shops • Heavy-duty dealerships • Fleet services facilities • In-plant • Lube trucks • Mining | – | <ul style="list-style-type: none"> • 35 ft (11 m) • 50 ft (15 m) • 95 ft (29 m) | Optional | 229-232 |
| XD™ 10 / 20 Series  | <ul style="list-style-type: none"> • Heavy-duty truck dealers • Fleet maintenance • Mining maintenance • Public works garage • Construction vehicle maintenance • Heavy-duty mobile service trucks • Mining • Lube trucks | <ul style="list-style-type: none"> • Petroleum- and synthetic-based oils • Air • Water • Grease • Antifreeze • Windshield washer fluid | <ul style="list-style-type: none"> • 35 ft (11 m) • 50 ft (15 m) • 65 ft (20 m) | Optional | 233-237 |
| XD™ 30 Series  | <ul style="list-style-type: none"> • Heavy-duty truck dealers • Fleet maintenance • Mining maintenance • Public works garage • Construction vehicle maintenance • Heavy-duty mobile service trucks • Mining • Lube trucks | <ul style="list-style-type: none"> • Petroleum- and synthetic-based oils • Diesel fuel • Air • Water • Grease • Antifreeze • Windshield washer fluid • Pressure wash • Waste oil evacuation • Diesel exhaust fluid (DEF) | <ul style="list-style-type: none"> • 35 ft (11 m) • 50 ft (15 m) • 65 ft (20 m) • 75 ft (23 m) | No | 238-242 |
| XD™ 40 / 50 Series  | <ul style="list-style-type: none"> • Heavy-duty truck dealers • Fleet maintenance • Mining maintenance • Public works garages • Construction vehicle maintenance • Heavy-duty mobile service trucks • Agriculture • Lube trucks | <ul style="list-style-type: none"> • Petroleum- and synthetic-based oils • Diesel fuel • Air • Water • Antifreeze • Waste oil evacuation | <ul style="list-style-type: none"> • 35 ft (11 m) • 50 ft (15 m) • 75 ft (23 m) • 100 ft (30 m) | No | 243-248 |
| XD™ 60 / 70 / 80 Series  | <ul style="list-style-type: none"> • Heavy-duty truck dealers • Fleet maintenance • Mining maintenance • Public works garages • Construction vehicle maintenance • Heavy-duty mobile service trucks • Agriculture • Lube trucks | <ul style="list-style-type: none"> • Petroleum- and synthetic-based oils • Diesel fuel • Air • Water • Grease • Waste oil evacuation | <ul style="list-style-type: none"> • 50 ft (15 m) • 75 ft (23 m) • 100 ft (30 m) • 150 ft (46 m) | No | 250-259 |

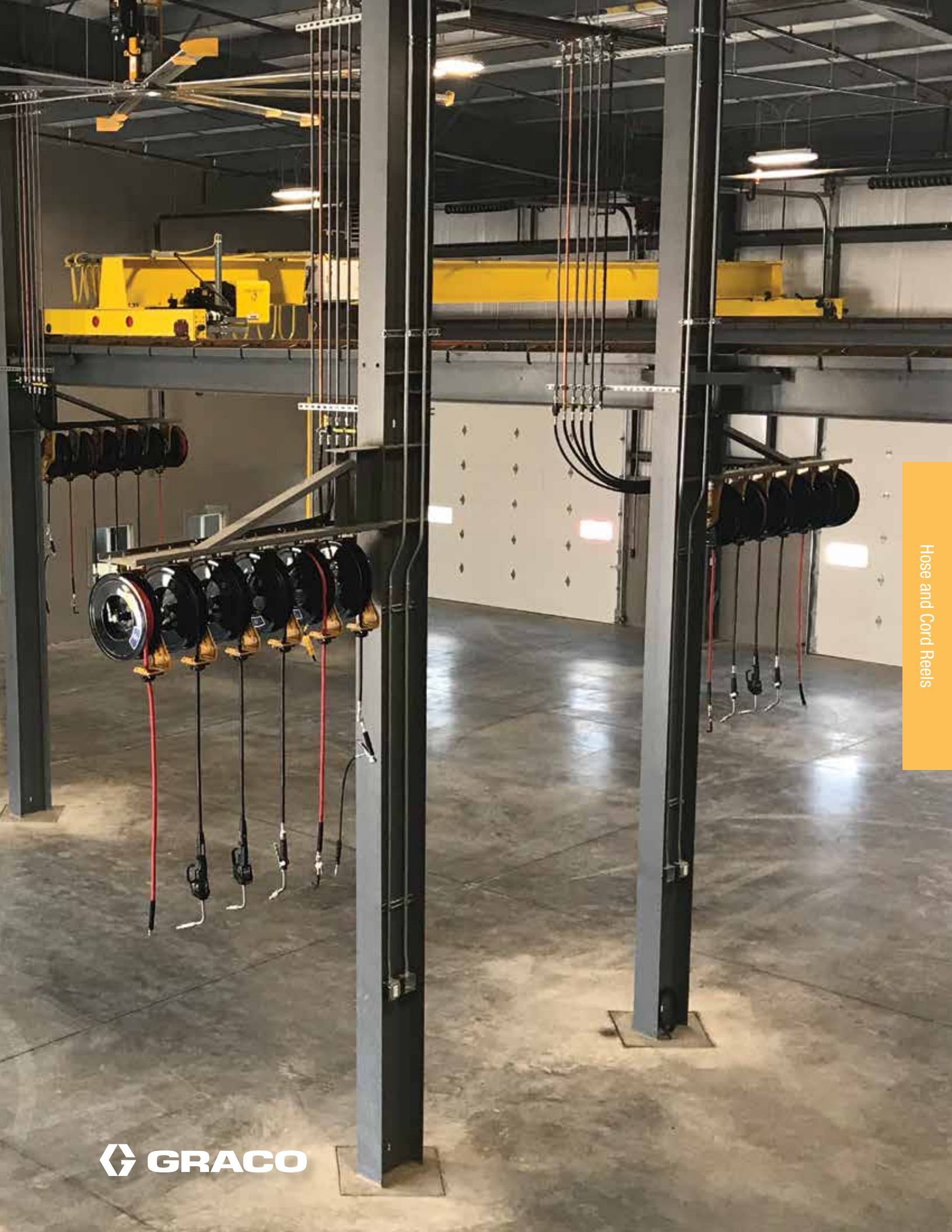

Hose and Cord Reels

LD Series Enclosed Hose Reels



**5 Year
Warranty!**

Economical Enclosed Hose Reels Get You Up and Running Fast

Reduce clutter and increase workplace safety with a Graco one-piece enclosed hose reel. Designed for light-duty applications in dealerships, service garages, collision repair and industrial manufacturing facilities.



Large Fluid Porting

Maximizes fluid flow with minimal pressure drop

Simple Spring Tension Adjustment

Ability to increase or decrease spring tension while reel is pressurized

Full Enclosure

Tough, dent-proof, corrosion-resistant enclosure

Multiple Mounting Options

Wall, overhead, bench, or tank configurations (wall mount pictured)

Hose and Cord Reels

Typical Applications

- Small maintenance shops
- Tire maintenance shops
- Small fast lubes
- Independent repair facilities
- Industrial manufacturing facilities

Typical Fluids Handled

- Petroleum- and synthetic-based oils (motor, gear and ATF)
- Air
- Water
- Grease
- Antifreeze
- Windshield washer fluid

Dimensions

| | |
|---|------------------|
| A | 7.1 in (180 mm) |
| B | 23.0 in (585 mm) |
| C | 18.5 in (470 mm) |
| D | 25.6 in (650 mm) |

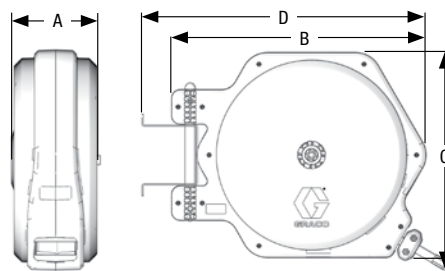

Technical Specifications

Operating Temperature Range

| | |
|------------------------|-------------------------------|
| Air-Only Reels | 14°F to 140°F (-10°C to 60°C) |
| Water Applications | 32°F to 140°F (0°C to 60°C) |
| All-Other Applications | 0°F to 140°F (-18°C to 60°C) |

Wetted Parts

| | |
|--|-----------------------------------|
| Air Only Reels | Aluminum, Buna-N rubber, PVC |
| Air/Water/Antifreeze/Windshield Washer Fluid Reels | Aluminum, Buna-N rubber |
| Oil Reels | Carbon steel, Buna-N rubber, PTFE |
| Grease Reels | Carbon steel, Buna-N rubber |

| | |
|----------------------|------------|
| Sound Pressure Level | 69.3 dB(A) |
| Sound Power Level | 75.3 dB(A) |
| Instruction Manual | 313938 |





LD Series Enclosed Hose Reels

Ordering Information

LD Series Reel Packages

Includes hose with ball stop kit and hose guide, mounting bracket and hose inlet kit.

| Type of Mount | Fluid | Hose | | Connection Size | | Maximum Pressure psi (bar) | Package Part Number | Package Includes | | |
|--|---|------------|---------------|-----------------|----------------|----------------------------|---------------------|------------------|-----------|-----------|
| | | ID in (mm) | Length ft (m) | Inlet in (mm) | Outlet in (mm) | | | Reel Assembly | Mount Kit | Inlet Kit |
|  <p><i>Overhead/Wall Swivel Mount</i></p> | Air/Water/ Antifreeze/ Windshield Washer Fluid | 3/8 (10) | 35 (11) | 1/2 (13) | 3/8 (10) | 250 (17.2) | 24F737 | 24H657 | 24G866 | 24C444 |
| | | 3/8 (10) | 50 (15) | 1/2 (13) | 3/8 (10) | 250 (17.2) | 24F738 | 24H658 | | |
| | | 1/2 (13) | 35 (11) | 1/2 (13) | 1/2 (13) | 250 (17.2) | 24F739 | 24H659 | | |
| | | 1/2 (13) | 50 (15) | 1/2 (13) | 1/2 (13) | 250 (17.2) | 24F740 | 24H660 | | |
| | Oil | 3/8 (10) | 35 (11) | 1/2 (13) | 3/8 (10) | 1,800 (124) | 24F741 | 24H661 | | 24C537 |
| | | 1/2 (13) | 35 (11) | 1/2 (13) | 1/2 (13) | 1,800 (124) | 24F742 | 24H662 | | 24C538 |
| | Grease | 1/4 (6) | 35 (11) | 3/8 (10) | 1/4 (6) | 5,000 (345) | 24F743 | 24H663 | | 24C539 |
|  <p><i>Overhead/Wall Stationary Mount</i></p> | Air/Water/ Antifreeze/ Windshield Washer Fluid | 3/8 (10) | 35 (11) | 1/2 (13) | 3/8 (10) | 250 (17.2) | 24F755 | 24H657 | 24G865 | 24C444 |
| | | 3/8 (10) | 50 (15) | 1/2 (13) | 3/8 (10) | 250 (17.2) | 24F756 | 24H658 | | |
| | | 1/2 (13) | 35 (11) | 1/2 (13) | 1/2 (13) | 250 (17.2) | 24F757 | 24H659 | | |
| | | 1/2 (13) | 50 (15) | 1/2 (13) | 1/2 (13) | 250 (17.2) | 24F758 | 24H660 | | |
| | Oil | 3/8 (10) | 35 (11) | 1/2 (13) | 3/8 (10) | 1,800 (124) | 24F759 | 24H661 | | 24C537 |
| | | 1/2 (13) | 35 (11) | 1/2 (13) | 1/2 (13) | 1,800 (124) | 24F760 | 24H662 | | 24C538 |
| | Grease | 1/4 (6) | 35 (11) | 3/8 (10) | 1/4 (6) | 5,000 (345) | 24F761 | 24H663 | | 24C539 |
|  <p><i>Bench Swivel Mount</i></p> | Air/Water/ Antifreeze/ Windshield Washer Fluid | 3/8 (10) | 35 (11) | 1/2 (13) | 3/8 (10) | 250 (17.2) | 24F773 | 24H657 | 24C772 | 24C444 |
| | | 3/8 (10) | 50 (15) | 1/2 (13) | 3/8 (10) | 250 (17.2) | 24F774 | 24H658 | | |
| | | 1/2 (13) | 35 (11) | 1/2 (13) | 1/2 (13) | 250 (17.2) | 24F775 | 24H659 | | |
| | | 1/2 (13) | 50 (15) | 1/2 (13) | 1/2 (13) | 250 (17.2) | 24F776 | 24H660 | | |
| | Oil | 3/8 (10) | 35 (11) | 1/2 (13) | 3/8 (10) | 1,800 (124) | 24F777 | 24H661 | | 24C537 |
| | | 1/2 (13) | 35 (11) | 1/2 (13) | 1/2 (13) | 1,800 (124) | 24F778 | 24H662 | | 24C538 |
| | Grease | 1/4 (6) | 35 (11) | 3/8 (10) | 1/4 (6) | 5,000 (345) | 24F779 | 24H663 | | 24C539 |

Hose and Cord Reels

LD Series Enclosed Hose Reels



Ordering Information

LD Series Reel

Includes hose. Mounting hardware and hose inlet kit sold separately.

| | Fluid | Hose | | Connection Size | | Maximum Pressure psi (bar) | Part Number | Hose Inlet Kit (order separately) |
|---|---|------------|---------------|-----------------|----------------|-------------------------------|-------------|--------------------------------------|
| | | ID in (mm) | Length ft (m) | Inlet in (mm) | Outlet in (mm) | | | |
|  | Air/Water/ Antifreeze/ Windshield Washer Fluid | 3/8 (10) | 35 (11) | 1/2 (13) | 3/8 (10) | 250 (17.2) | 24H657 | 24C444 |
| | | 3/8 (10) | 50 (15) | 1/2 (13) | 3/8 (10) | 250 (17.2) | 24H658 | 24C444 |
| | | 1/2 (13) | 35 (11) | 1/2 (13) | 1/2 (13) | 250 (17.2) | 24H659 | 24C444 |
| | | 1/2 (13) | 50 (15) | 1/2 (13) | 1/2 (13) | 250 (17.2) | 24H660 | 24C444 |
| | Oil | 3/8 (10) | 35 (11) | 1/2 (13) | 3/8 (10) | 1,800 (124) | 24H661 | 24C537 |
| | | 1/2 (13) | 35 (11) | 1/2 (13) | 1/2 (13) | 1,800 (124) | 24H662 | 24C538 |
| | Grease | 1/4 (6) | 35 (11) | 3/8 (10) | 1/4 (6) | 5,000 (345) | 24H663 | 24C539 |

Hose Inlet Kits

A hose inlet kit is included in LD reel packages but must be ordered separately with standalone LD reel assemblies.

| | Fluid Type | Maximum Working Pressure psi (bar) | Size In (mm) | Inlet Configuration | Outlet Configuration | Part Number | Used with Hose Reel Model |
|--|-------------|---------------------------------------|-----------------|------------------------|-------------------------|-------------|------------------------------|
|  | Air Only | 250 (17.2) | 1/4 (6) | 1/4 NPT(M) | 1/4 NPT(M) | 24C443 | 24H655 / 24H656 |
| | Air/Water | | 3/8 (10) | 1/2 NPT(M) | 3/8 NPT(M) | 24C444 | 24H657 / 24H658 |
| | | | 1/2 (13) | 1/2 NPT(M) | 1/2 NPT(M) | | 24H659 / 24H660 |
| | Oil | 1,800 (124) | 3/8 (10) | 1/2 NPT(M) | 1/2 NPT(M) | 24C537 | 24H661 |
| | | | 1/2 (13) | 1/2 NPT(M) | 1/2 NPT(M) | 24C538 | 24H662 |
| Grease | 5,000 (345) | 1/4 (6) | 1/4 NPT(M) | 1/4 NPT(M) | 24C539 | 24H663 | |



The Ultimate Industrial-Grade Hose Reel

Designed with an all-metal frame and specially crafted components; Graco LDX hose reels ensure smooth release and retraction to optimize confidence in cost-conscious smaller garages, independent repair facilities and industrial manufacturing environments.

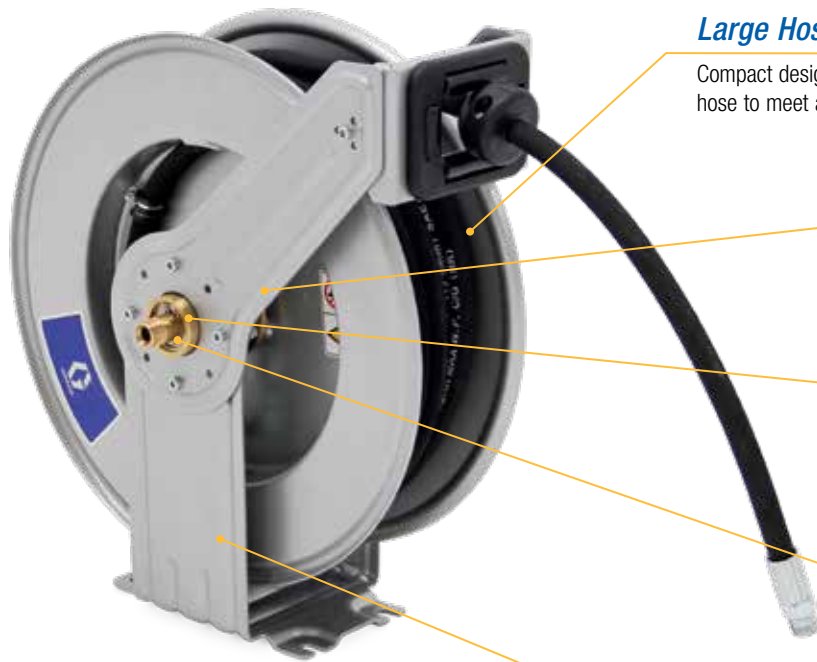

Large Hose Capacity with Small Profile

Compact design accommodates up to a 50 foot (15 meter) hose to meet a wide variety of application requirements.

Adjustable Arm

Easily change to one of six arm positions to fit your application.

Ball Bearing Swivel

Swivel designed with internal ball bearings reduces friction and ensures smooth operation.

External Swivel Housing

Quickly access swivel seal for faster repairs.

Dual Pedestal Frame

Ribbed metal for increased stability and robustness.

Typical Applications

- Industrial manufacturing facilities
- Small maintenance shops
- Tire maintenance shops
- Small fast lubes
- Independent repair facilities

Typical Fluids Handled

- Petroleum- and synthetic-based oils (motor, gear and ATF)
- Air
- Water
- Grease
- Antifreeze
- Windshield washer fluid
- Diesel exhaust fluid (DEF)

Technical Specifications

Operating Temperature Range

| | |
|--|---------------------------------|
| Air/Water/Antifreeze/Windshield Washer Fluid | 14.5°F to 149°F (-26°C to 65°C) |
| DEF | -40°F to 158°F (-40°C to 70°C) |
| Oil | -40°F to 212°F (-40°C to 100°C) |
| Grease | -40°F to 212°F (-40°C to 100°C) |

Wetted Parts

| | |
|--|--|
| Air/Water/Antifreeze/Windshield Washer Fluid Reels | EPDM, stainless steel, fluorocarbon (FKM) |
| DEF Reels | Hybrid polymer, brass, nitrile rubber |
| Oil Reels | Zinc-plated steel, brass, polyurethane, nitrile rubber |
| Grease Reels | Zinc-plated steel, brass, nitrile rubber |

| | |
|----------------------|----------|
| Sound Pressure Level | 80 dB(A) |
| Sound Power Level | 87 dB(A) |
| Instruction Manual | 3A8216 |

LDX Series Hose Reels



Dimensions

| | |
|---|------------------|
| A | 3.5 in (89 mm) |
| B | 7.5 in (191 mm) |
| C | 4.9 in (125 mm) |
| D | 8.7 in (221 mm) |
| E | 19.0 in (483 mm) |
| F | 9.4 in (239 mm) |
| G | 17.5 in (445 mm) |

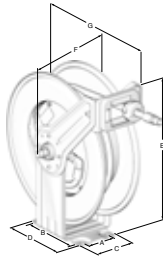

Typical Mounting Configurations



Overhead Mount

Wall Mount



Bench Mount

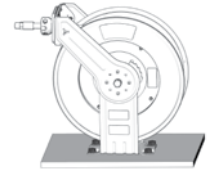

Ordering Information

LDX Reels

| Part Number | Fluid | Hose | | Connection Size | | Maximum Pressure PSI |
|-------------|--|---------|-------------|-----------------|-------------|----------------------|
| | | ID (in) | Length (ft) | Inlet (in) | Outlet (in) | |
| HEL010 | Air/Water/Antifreeze/Windshield Washer Fluid | 3/8 | 50 | 3/8 NPT | 3/8 NPT | 300 |
| HEL012 | Air/Water/Antifreeze/Windshield Washer Fluid | 3/8 | 50 | 3/8 NPT | 1/4 NPT | 300 |
| HEL015 | DEF | 1/2 | 45 | 1/2 BSPT | 1/2 BSPT | 150 |
| HEM004 | Oil | 1/2 | 50 | 1/2 NPT | 1/2 NPT | 1,500 |
| HEH006 | Grease | 3/8 | 50 | 3/8 NPT | 3/8 NPT | 4,060 |

Inlet Kits

| Part Number | Fluid |
|-------------|--|
| 25U369 | Air/Water/Antifreeze/Windshield Washer Fluid |
| 25U370 | DEF |
| 25U371 | Oil |
| 25U372 | Grease |

Accessories

| Part Number | Description |
|-------------|---|
| 18F444 | 1/2 in BSPT to 3/4 in hose barb adapter |
| 18F445 | 1/2 in to 3/4 in adapter, BSPT |



**7 Year
Warranty!**

High-Quality Performance and Versatility

Improve performance along with the look of any environment with Graco's flagship SDX hose reel. Built with specially crafted components, including a rigid metal frame and spool and effortless retraction swivels, it's available in five colors. An easy-to-service swivel cartridge design simplifies maintenance. Retraction and recoil are uniform and consistent every time.



Reel arm shown in tank/bench mount position.

Adjustable Arm

Easily change to one of six arm positions to fit your application.

Durable Finish

Baked-on enamel finish (five colors available) protects reel from corrosion.

Large Hose Capacity with Small Profile

Compact pedestal and spool fits into tight spaces and can accommodate 35-65 foot (10.7-19.8 meters) hose (NPT air/water) capacity for a wide variety of applications.

Heavy-Duty Spring

Powerful retraction performance ensures recoils are uniform and consistent every time.

Full-Flow Swivel

Maximize material flow with minimal pressure drop for faster fills to get more vehicles through your shop.

Low-Friction Cartridge Swivel

Provides smooth reel performance with an easy-to-replace swivel cartridge, simplifying repairs.

Hose and Cord Reels

Typical Applications

- Car dealerships
- Light-/medium-duty truck dealers
- Fleet maintenance
- Public works garages
- Construction vehicle maintenance
- Light-utility service trucks

Typical Fluids Handled

- Petroleum- and synthetic-based oils (motor, gear and ATF)
- Air
- Water
- Grease
- Antifreeze/coolant
- Windshield washer fluid

Technical Specifications

Operating Temperature Range

| | |
|--|--------------------------------|
| Air/Water/Antifreeze/Windshield Washer Fluid Reels | -20°F to 190°F (-28°C to 87°C) |
| Oil Reels | -20°F to 190°F (-28°C to 87°C) |
| Grease Reels | -40°F to 200°F (-40°C to 93°C) |

Wetted Parts

| | |
|--|---|
| Air/Water/Antifreeze/Windshield Washer Fluid Reels | Zinc-plated steel, stainless steel, anodized aluminum, nitrile rubber |
| Oil Reels | Zinc-plated steel, anodized aluminum, nitrile rubber |
| Grease Reels | Zinc-plated steel, nitrile rubber, steel |

Weight 52 lb (23.5 kg)

Sound Pressure Level 80 dB(A)

Sound Power Level 87 dB(A)

Instruction Manual 3A8626

SDX Series Hose Reels



| Dimensions | | |
|------------|------------------|------------------|
| | SDX 10 | SDX 20 |
| A | 7.0 in (177 mm) | 7.0 in (177 mm) |
| B | 16.2 in (412 mm) | 18.1 in (460 mm) |
| C | 21.0 in (533 mm) | 23.4 in (594 mm) |
| D | 17.1 in (435 mm) | 19.2 in (488 mm) |
| E | 19.5 in (495 mm) | 21.8 in (554 mm) |
| F | 22.5 in (571 mm) | 25.2 in (640 mm) |

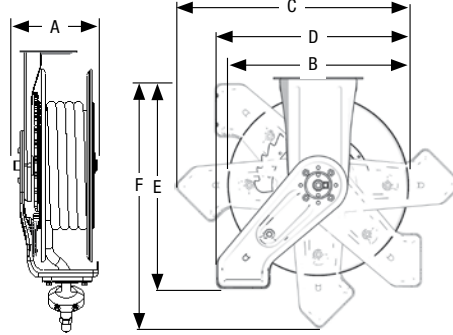

Typical Mounting Configurations

Overhead Mount

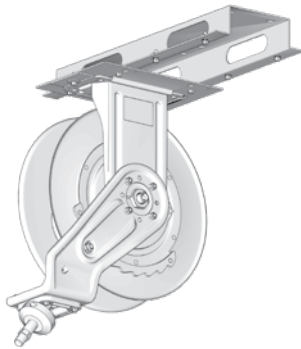

Wall Mount

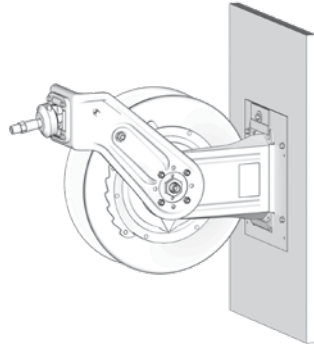

Bench/ Truck Mount

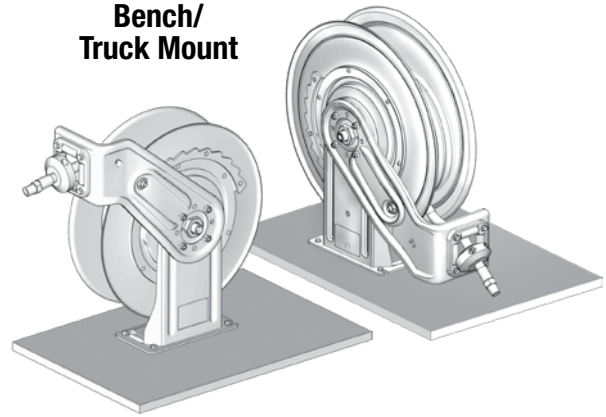

Metallic Blue (B)

Yellow (F)

Black (D)

Red (C)

White (A)

Available in
5 Colors
Consult factory for
lead times.





Ordering Information

SDX 10/20 Reel Assembly Ordering Guide

SDX Series reels are available in five colors. Use the chart below to determine the correct part number to order. The last character of each part number indicates the hose reel color.

| Reel Color | Identifier |
|---------------|------------|
| White | A |
| Metallic Blue | B |
| Red | C |
| Black | D |
| Yellow | F |

Order Example:

Arm in overhead mount position, SDX 20, oil, 1/2 in ID hose, 50 ft hose length

1 Select your reel position: SDM65#

2 Select your reel color: Metallic Blue = "B"
(from Reel Assembly Ordering Guide – opposite)

Order Part Number:

SDM65B



Arm in Overhead Mount Position

Assembled with hose, ball stop kit and roller guide. *Required hose inlet kit sold separately.*

| | Reel Size | Fluid | Hose | | Connection Size | | Maximum Pressure psi (bar) | Assembly Part Number | Recommended Hose Inlet Kit |
|--------|-----------|---|------------|---------------|-----------------|----------------|----------------------------|----------------------|----------------------------|
| | | | ID in (mm) | Length ft (m) | Inlet in (mm) | Outlet in (mm) | | | |
| | SDX 10 | Air/Water/ Antifreeze/ Windshield Washer Fluid | 3/8 (10) | 35 (11) | 1/2 (13) | 3/8 (10) | 300 (20.7) | SDL23# | 218549 |
| | | | 3/8 (10) | 50 (15) | 1/2 (13) | 3/8 (10) | 300 (20.7) | SDL25# | |
| | | | 1/2 (13) | 35 (11) | 1/2 (13) | 1/2 (13) | 300 (20.7) | SDL33# | |
| | SDX 20 | | 3/8 (10) | 65 (20) | 1/2 (13) | 3/8 (10) | 300 (20.7) | SDL56# | |
| | | | 1/2 (13) | 50 (15) | 1/2 (13) | 1/2 (13) | 300 (20.7) | SDL65# | |
| | SDX 10 | | Oil | 1/2 (13) | 35 (11) | 1/2 (13) | 1/2 (13) | 2,000 (138) | |
| SDX 20 | | 1/2 (13) | | 50 (15) | 1/2 (13) | 1/2 (13) | 2,000 (138) | SDM65# | |
| SDX 10 | Grease | 1/4 (6) | 50 (15) | 3/8 (10) | 1/4 (6) | 5,000 (345) | SDH15# | 218550 | |
| | | 3/8 (10) | 35 (11) | 3/8 (10) | 1/4 (6) | 4,800 (331) | SDH23# | | |
| | | SDX 20 | 3/8 (10) | 50 (15) | 3/8 (10) | 1/4 (6) | 4,800 (331) | | SDH55# |

Arm in Tank/Bench Mount Position

Assembled with hose, ball stop kit and roller guide. *Required hose inlet kit sold separately.*

| | Reel Size | Fluid | Hose | | Connection Size | | Maximum Pressure psi (bar) | Assembly Part Number | Recommended Hose Inlet Kit |
|--|-----------|---|------------|---------------|-----------------|----------------|----------------------------|----------------------|----------------------------|
| | | | ID in (mm) | Length ft (m) | Inlet in (mm) | Outlet in (mm) | | | |
| | SDX 20 | Air/Water/ Antifreeze/ Windshield Washer Fluid | 3/8 (10) | 65 (20) | 1/2 (13) | 3/8 (10) | 300 (20.7) | SDL5J# | 218549 |
| | | | 1/2 (13) | 50 (15) | 1/2 (13) | 1/2 (13) | 300 (20.7) | SDL6H# | |
| | | Oil | 1/2 (13) | 50 (15) | 1/2 (13) | 1/2 (13) | 2,000 (138) | SDM6H# | 218550 |
| | | Grease | 3/8 (10) | 50 (15) | 3/8 (10) | 1/4 (6) | 4,800 (331) | SDH5H# | |

SDX Series Hose Reels



Ordering Information



Bare Reels

Arm in Overhead Mount Position

Required hose inlet kit sold separately. Fluid hose not included.

| | Reel Size | Fluid | Hose (Not Included) | | Connection Size | | Maximum Pressure psi (bar) | Assembly Part Number | Recommended Hose Inlet Kit | |
|---|-----------|---|---------------------|---------------|-----------------|----------------|----------------------------|----------------------|----------------------------|--------|
| | | | ID in (mm) | Length ft (m) | Inlet in (mm) | Outlet in (mm) | | | | |
|  | SDX 10 | Air/Water/ Antifreeze/ Windshield Washer Fluid | 3/8 (10) | 50 (15) | 1/2 (13) | 3/8 (10) | 300 (20.7) | SDL2D# | 218549 | |
| | | | 1/2 (13) | 35 (11) | 1/2 (13) | 3/8 (10) | 300 (20.7) | SDL2D# | | |
| | SDX 20 | | 3/8 (10) | 65 (20) | 1/2 (13) | 1/2 (13) | 300 (20.7) | SDL6D# | | |
| | | | 1/2 (13) | 50 (15) | 1/2 (13) | 1/2 (13) | 300 (20.7) | SDL6D# | | |
| | SDX 10 | Oil | 1/2 (13) | 35 (11) | 1/2 (13) | 1/2 (13) | 2,000 (138) | SDM3B# | | 218550 |
| | | | SDX 20 | 1/2 (13) | 50 (15) | 1/2 (13) | 1/2 (13) | 2,000 (138) | | |
| SDX 10 | Grease | 1/4 (6) | 50 (15) | 3/8 (10) | 3/8 (10) | 5,000 (345) | SDH1D# | | | |
| | | SDX 20 | 3/8 (10) | 35 (11) | 3/8 (10) | 3/8 (10) | 5,000 (345) | SDH1D# | | |
| | | SDX 20 | 3/8 (10) | 50 (15) | 3/8 (10) | 3/8 (10) | 5,000 (345) | SDH5D# | | |

SDX 10 Oil Reel Packages

| | Reel Size | Fluid | Valve Type | Enclosure | Package Number | Package Includes | | | | |
|---|-----------|-------|--|---|----------------|------------------|-----------|----------------|--------|--------|
| | | | | | | Reel Assembly | Enclosure | Hose Inlet Kit | Meter | |
|  | SDX 10 | Oil | SDM8 Manual Meter with Rigid Extension | No | 24E001 | SDM33B | - | 218549 | 25M404 | |
| | | | | Yes | 24D996 | SDM33B | 24A217 | 218549 | 25M404 | |
|  | | | None | SDM8 Manual Meter with Flexible Extension | No | 24E002 | SDM33B | - | 218549 | 25M406 |
| | | | | | Yes | 24D997 | SDM33B | 24A217 | 218549 | 25M406 |
|  | | | None | None | Yes | 24D995 | SDM33B | 24A217 | 218549 | - |



Ordering Information

SDX 10 Air/Water Reel Packages

| | Reel Size | Fluid | Valve Type | Enclosure | Package Number | Package Includes | | | | |
|--|-----------|-----------|--------------------------|-----------|----------------|------------------|-----------|----------------|--------|---------|
| | | | | | | Reel Assembly | Enclosure | Hose Inlet Kit | Valve | Fitting |
| | SDX 10 | Water | Water Bib Dispense Valve | No | 24D999 | SDL23B | - | 218549 | 180685 | 150287 |
| | | | | Yes | 24D993 | SDL23B | 24A217 | 218549 | 180685 | 150287 |
| | | | | | 24D994 | SDL33B | 24A217 | 218549 | 180685 | 159842 |
| | SDX 10 | Air | Tire Chuck Valve | No | 24D998 | SDL23B | - | 218549 | 218545 | - |
| | | | | Yes | 24D992 | SDL23B | 24A217 | 218549 | 218545 | - |
| | SDX 10 | Air/Water | None | Yes | 24D989 | SDL23B | 24A217 | 218549 | - | - |
| | | | | | 24D990 | SDL25B | 24A217 | 218549 | - | - |
| | | | | | 24D991 | SDL33B | 24A217 | 218549 | - | - |

Hose and Cord Reels

Accessories

Enclosure Kits for One Reel

Open mounting accommodates up to six reels. Includes all parts necessary to mount on wall or overhead. Requires mounting channel.

| | Reel Size | White | Metallic Blue | Red | Black | Dark Blue | Yellow | Required End-Caps (set of 2) |
|--|-----------|--------|---------------|--------|--------|-----------|--------|------------------------------|
| | SDX 10 | 24A217 | 24A940 | 24A941 | 24A942 | 24A943 | 24A944 | 24A950 |
| | SDX 20 | 24A218 | 24A945 | 24A946 | 24A947 | 24A948 | 24A949 | 24A951 |

Hose Inlet Kits

A hose inlet kit is required when ordering an SDX reel.

| | Maximum Working Pressure psi (bar) | Size in (mm) | Length ft (m) | Part Number |
|--|------------------------------------|--------------|---------------|-------------|
| | 2,000 (137) | 1/2 (13) | 2 (0.6) | 218549 |
| | 4,000 (276) | 3/8 (10) | | 218550 |
| | 5,000 (345) | 1/4 (6) | | 224417 |

Ball Stop Kits

SDX reel packages include ball stop kits. Items below are available for bare reels and as replacement parts.



| | Hose Inner Diameter (ID) Size | Part Number |
|--|--------------------------------------|-------------|
| | 1/4 in (6.4 mm) | 222225 |
| | 1/4 in to 3/8 in (6.4 mm to 9.5 mm) | 218340 |
| | 3/8 in to 1/2 in (9.5 mm to 12.7 mm) | 218341 |
| | 5/8 in (15.9 mm) | 237872 |



Ordering Information

Mounting Channels

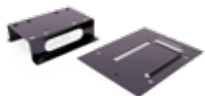
Accommodates up to six reels. Includes all parts necessary to mount on wall or overhead.

| | Description | 1 Reel | 2 Reels | 3 Reels | 4 Reels | 5 Reels | 6 Reels |
|---|--------------------------------|--------------|---------|---------|--------------|---------|---------|
|  | Enclosed Reel Mounting Channel | 203521 | 203522 | 203523 | 203524 | 203525 | 203526 |
|  | Open Reel Mounting Channel | 24A934 | 24A935 | 24A936 | 24A937 | 24A938 | 24A939 |
|  | I-Beam Mounting Bracket* | 204741 (x 2) | | | 204741 (x 3) | | |

*Secures mounting channel to I-beam without drilling – 2 are required for 1-3 reels, and 3 are required for 4-6 reels.

Swivel Mounting Bracket

Allows reel to swivel 120° with two lockable positions.

| | Part Number | Description |
|--|-------------|---|
|  | 24N444 | Swivel mounting bracket for installing SDX 10 reels |

Easy Slide-In Mount

Allows reel to slide in and out of mount for easy installation.

| | Part Number | Description |
|---|-------------|--|
|  | 24H193 | Overhead or wall slide-in mount for SDX 10 or SDX 20 reels |

Retrofit Adapter Kits

| | Part Number | Description |
|---|-------------|---|
|  | 24C100 | Includes all parts to mount an SDX 10 hose reel to an existing 250 series mounting pattern with enclosure |

Hose Identification Wraps

Vinyl hose wrap for easy identification of meter fluid.

| | Part Number | Description |
|---|-------------|-------------|
|  | 17S659 | Red |
|  | 17S660 | Blue |
|  | 17S661 | Green |
|  | 17S662 | Yellow |
|  | 17S663 | White |

Quality Cord and Light Reels

Organize your work space for a safer, more productive work environment. Make Graco your single source for your entire reel bank.

**2 Year
Warranty!**

Durable Frame in Two Sizes

Choose from the heavy-duty steel construction of the SD Series 5 or 10.

Multiple Cord Lengths

Choose from 35, 50 and 95 foot (11, 15, 29 meter) options to fit your shop perfectly. Features a 5 foot lead-in cable.

Adjustable Arm

Easily change the arm position to fit more applications. Works on walls, overhead or bench mounts.

Heavy-Duty Pedestal

High-strength steel construction with rolled edges and ribbed stress points that won't flex or twist.

Multiple Configurations Available

Comes with or without receptacles so you can configure it for your specific needs. Light reels come in your choice of fluorescent or LED with optional tool tap receptacle.



Hose and Cord Reels

Typical Applications

- Automotive dealerships
- Fast lube centers
- Service shops
- Heavy-duty dealerships
- Fleet services facilities
- In-plant
- Lube trucks
- Mining

Dimensions

| | SD Series 5 | SD Series 10 |
|---|-------------------|------------------|
| A | 3.5 in (89 mm) | 3.5 in (89 mm) |
| B | 6.38 in (162 mm) | 7.5 in (191 mm) |
| C | 4.7 in (120 mm) | 4.7 in (120 mm) |
| D | 7.48 in (190 mm) | 9 in (229 mm) |
| E | 14.8 in (376 mm) | 19.5 in (498 mm) |
| F | 6.6 in (168 mm) | 7 in (177 mm) |
| G | 13.84 in (352 mm) | 17.5 in (445 mm) |

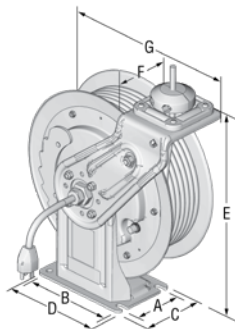

Technical Specifications

Operating Temperature Range

| | |
|-------------|-----------------------------------|
| Cord Reels | -22°F to 122°F (-30°C to 50°C) |
| Light Reels | -4°F to 104°F (-20°C to 40°C) |

Weight without Accessories

| | | | |
|------|-------|----------------------|---------|
| 120V | SD 5 | 16 AWG, Length 35 ft | 25.4 lb |
| | | 16 AWG, Length 50 ft | 27.6 lb |
| | SD 10 | 12 AWG, Length 35 ft | 28.2 lb |
| | | 12 AWG, Length 50 ft | 32.0 lb |
| | | 16 AWG, Length 95 ft | 46.3 lb |
| | | 12 AWG, Length 95 ft | 51.8 lb |

Instruction Manual | 3A2592

SD Series Cord and Light Reels

Ordering Information

SD Cord and Light Reels – 120 Volt

120 volt cord and light reels have a black finish and are ETL approved to US and CSA standards.

| Accessory | Reel Size | AWG | Amp | Cord Length | Insulation | Part Number |
|--|-----------|-----|-----|--------------|------------|-------------|
| No Accessory – Cord Only | SD 5 | 12 | 20 | 50 ft (15 m) | SJOOW | 24Y859 |
| | SD 10 | 12 | 18 | 95 ft (29 m) | SJOOW | 24Y880 |
| | SD 5 | 16 | 13 | 50 ft (15 m) | SJTOW | 24Y861 |
| Single Industrial Receptacle | SD 5 | 12 | 20 | 35 ft (11 m) | SJOOW | 24Y862 |
| | SD 5 | 12 | 20 | 50 ft (15 m) | SJOOW | 24Y863 |
| | SD 10 | 12 | 18 | 95 ft (29 m) | SJOOW | 24Y882 |
| Tri-Plug GFCI Industrial Receptacle | SD 5 | 12 | 15 | 50 ft (15 m) | SJOOW | 24Y864 |
| | SD 10 | 12 | 15 | 95 ft (29 m) | SJOOW | 24Y883 |
| Fluorescent Light | SD 5 | 16 | <1 | 35 ft (11 m) | SJTOW | 24Y865 |
| | SD 5 | 16 | <1 | 50 ft (15 m) | SJTOW | 24Y866 |
| | SD 10 | 16 | <1 | 95 ft (29 m) | SJTOW | 24Y884 |
| Fluorescent Light with Single Tool Tap Plug | SD 5 | 16 | 10 | 50 ft (15 m) | SJTOW | 24Y868 |
| LED Light | SD 5 | 16 | <1 | 35 ft (11 m) | SJTOW | 24Y869 |
| | SD 5 | 16 | <1 | 50 ft (15 m) | SJTOW | 24Y870 |
| | SD 10 | 16 | <1 | 95 ft (29 m) | SJTOW | 24Y886 |
| LED Light with In-line Tool Tap | SD 5 | 16 | 12 | 35 ft (11 m) | SJTOW | 24Y871 |
| | SD 5 | 16 | 12 | 50 ft (15 m) | SJTOW | 24Y872 |
| | SD 10 | 16 | 10 | 95 ft (29 m) | SJTOW | 24Y887 |

Accessory Ordering Information



Enclosure Kits

Includes an enclosure for one reel. A set of end-caps are required per single or bank of reels. Requires you to order Enclosed Reel Mounting Channel separately. For mounting SD 5 or SD 10 reels in size 20 enclosures, please see Adapter Kits on page 232.

|  | Reel Size | White | Metallic Blue | Red | Black | Dark Blue | Yellow | Required End-Caps (set of 2) |
|---|---------------------------------|--------|---------------|--------|--------|-----------|--------|------------------------------|
| | SD 5 with size 10 enclosure | 24N690 | 24N682 | 24N683 | 24N684 | 24N691 | 24N685 | 24A950 |
| | SD 10 with size 10 enclosure | 24A217 | 24A940 | 24A941 | 24A942 | 24A943 | 24A944 | 24A950 |

Mounting Channels

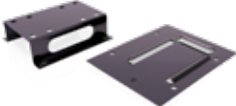
Accommodates up to six reels. Includes all parts necessary to mount on wall or overhead.

|  | Description | Reel Size | 1 Reel | 2 Reels | 3 Reels | 4 Reels | 5 Reels | 6 Reels |
|---|--------------------------------|----------------|--------------|---------|---------|--------------|---------|---------|
| | Enclosed Reel Mounting Channel | SD 5 and SD 10 | 203521 | 203522 | 203523 | 203524 | 203525 | 203526 |
|  | Open Reel Mounting Channel | SD 5 | 24N674 | 24N675 | – | – | – | – |
| | | SD 10 | 24A934 | 24A935 | 24A936 | 24A937 | 24A938 | 24A939 |
|  | I-Beam Mounting Bracket* | SD 5 and SD 10 | 204741 (x 2) | | | 204741 (x 3) | | |

*Secures mounting channel to I-beam without drilling – 2 are required for 1-3 reels, and 3 are required for 4-6 reels.

SD Series Cord and Light Reel Accessories

Ordering Information

Swivel Mounting Bracket

Allows reel to swivel 120° with two lockable positions.

|  | Reel Size | Part Number | Description |
|---|-----------|-------------|--|
| | SD 5 | 24N814 | Swivel mounting bracket for installation |
| | SD 10 | 24N444 | Swivel mounting bracket for installation |

Wall/Overhead Mounting Bracket

Allows you to slide the reel in and out for easy installation.

|  | Reel Size | Part Number | Description |
|---|-----------|-------------|------------------------------------|
| | SD 5 | 24N686 | Wall/overhead easy mount plate kit |
| | SD 10 | 24H193 | Wall/overhead easy mount plate kit |

Adapter Kits

|  | Part Number | Description |
|---|---|---|
| | 24P164 | Spacer bracket for mounting a size 5 reel to an existing size 10 enclosure |
| | 24P880 | Spacer bracket for mounting a size 5 reel to an existing size 20 enclosure |
| | 24P881 | Spacer bracket for mounting a size 10 reel to an existing size 20 enclosure |
| 16N883 | Clamping plate to mount a size 5 reel to an existing SD Series open channel | |

Hands-Free Magnetic Clip

Non-marring cover won't scratch vehicle finish. Snap onto light tube for hands-free operation.

|  | Part Number | Description |
|---|-------------|------------------------------|
| | 16P999 | Magnetic clip for light tube |



**7 Year
Warranty!**

Performance in the Most Demanding Applications

The heavy-duty XDX hose reels are designed to handle fluid delivery tasks in the harshest, most challenging environments. Built with specially crafted components to extend performance for many years, the hose reel includes a robust heavy-gauge, dual-pedestal metal frame; steel spool; sealed components; and unique swivel design to transport fluids consistently and safely without fail.

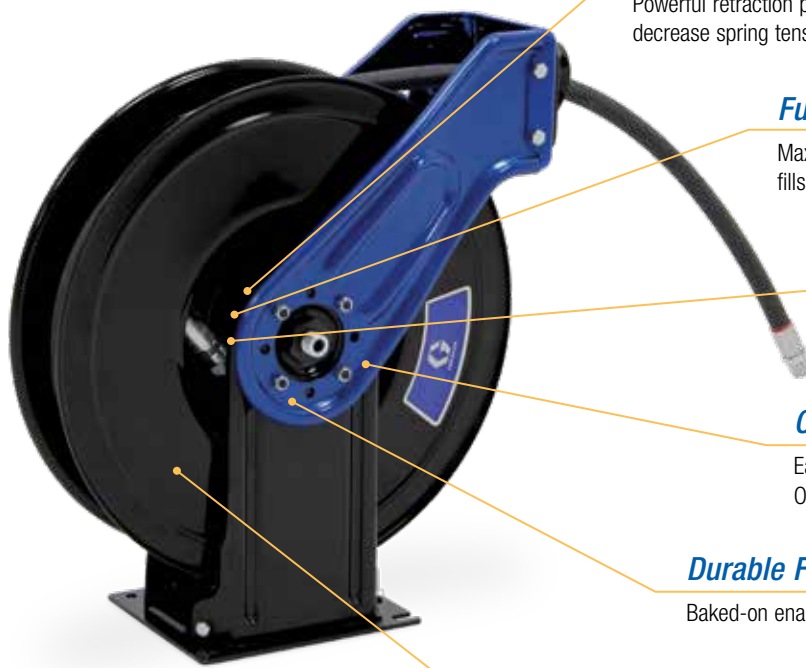

Heavy-Duty Adjustable Spring

Powerful retraction performance that allows you to easily increase or decrease spring tension while the reel is pressurized with fluid.

Full-Flow Swivel

Maximize material flow with minimal pressure drop for faster fills to get more vehicles through your shop.

Low-Friction Cartridge Swivel

Provides smooth reel performance with an easy-to-replace swivel cartridge, simplifying repairs.

Optional Adjustable Arm

Easily change to one of six arm positions to fit your application. Order with arm (XD models) or without (XN models).

Durable Finish

Baked-on enamel finish (four colors available) protects reel from corrosion.

Large Hose Capacity with Small Profile

Compact pedestal and spool fits into tight spaces and can accommodate 35-65 foot (10.7-19.8 meters) hose capacity for a wide variety of applications.

Hose and Cord Reels

Typical Applications

- Heavy-duty truck dealers
- Fleet maintenance
- Mining maintenance
- Public works garage
- Construction vehicle maintenance
- Heavy-duty mobile service trucks
- Mining
- Lube trucks

Typical Fluids Handled

- Petroleum- and synthetic-based oils (motor, gear and ATF)
- Air
- Water
- Grease
- Antifreeze/coolant
- Windshield washer fluid

Technical Specifications

Operating Temperature Range

| | |
|--|--------------------------------|
| Air/Water/Antifreeze/ Windshield Washer Fluid | -20°F to 190°F (-28°C to 87°C) |
| Oil | -20°F to 190°F (-28°C to 87°C) |
| Grease | -40°F to 200°F (-40°C to 93°C) |

Wetted Parts

| | |
|--|---|
| Air/Water/Antifreeze/ Windshield Washer Fluid | Zinc plated steel, stainless steel, anodized aluminum, nitrile rubber |
| Oil | Zinc plated steel, anodized aluminum, nitrile rubber |
| Grease | Zinc plated steel, polyurethane, steel |

Weight (Without Hose)

| | |
|---------------------------------|-----------------|
| HS Models (With Adjustable Arm) | 59 lb (26.5 kg) |
| HN Models (Without Arm) | 52 lb (23.5 kg) |

| | |
|----------------------|----------|
| Sound Pressure Level | 78 dB(A) |
| Sound Power Level | 88 dB(A) |
| Instruction Manual | 3A8626 |

XDX Series Hose Reels



10 / 20 / 20 XN

| Dimensions | | | |
|------------|------------------------------------|------------------|----------------------------|
| | XD Models (With Adjustable Arm) | | XN Models (Without Arm) |
| | XDX 10 | XDX 20 | XDX 20 |
| A | 7.5 in (196 mm) | 7.5 in (196 mm) | 7.5 in (196 mm) |
| B | 16.2 in (412 mm) | 18.1 in (460 mm) | 18.1 in (460 mm) |
| C | 21.0 in (533 mm) | 23.4 in (594 mm) | 23.4 in (594 mm) |
| D | 18.0 in (457 mm) | 20.0 in (508 mm) | 20.0 in (508 mm) |
| E | 18.5 in (470 mm) | 21.0 in (533 mm) | — |
| F | 22.5 in (571 mm) | 25.2 in (640 mm) | — |

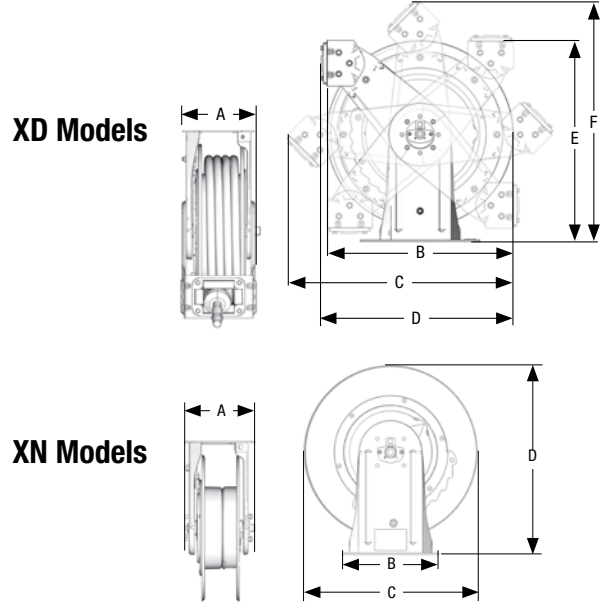

Typical Mounting Configurations

Overhead Mount

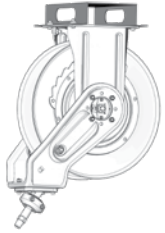

Wall Mount

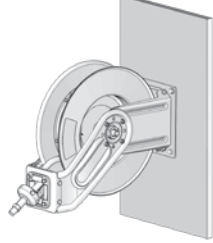

**Bench/
Truck Mount**

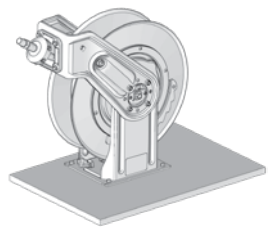

**Truck Mount with Remote
Mounted Roller Guide**



Available in
4 Colors
Consult factory for
lead times.

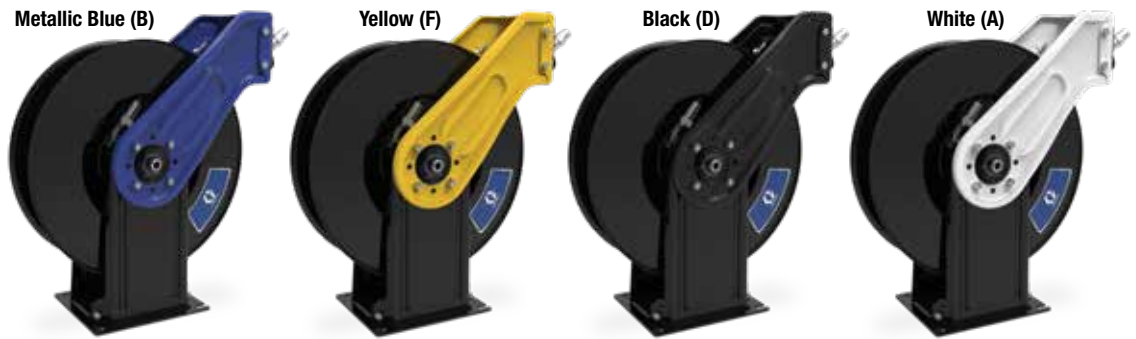

Hose and Cord Reels



Ordering Information

XDX 10/20 Reel Assembly Ordering Guide

XDX Series reels are available in three colors. Use the chart below to determine the correct part number to order. The last character of each part number indicates the hose reel color.

| Reel Color | Identifier |
|---------------|------------|
| White | A |
| Metallic Blue | B |
| Black | D |
| Yellow | F |

Order Example:

Arm in bench/truck mount position,
XDX 20, oil, 1/2 in ID hose, 50 ft hose length

- 1 Select your reel position:** XDM65#
- 2 Select your reel color:** Black = "D"
(from Reel Assembly Ordering Guide – opposite)

Order Part Number:

XDM65D



XD Models (with Adjustable Arm)

Reel Assemblies

Assembly includes hose, ball stop kit and roller guide. *Required hose inlet kit sold separately.*

| | Reel Size | Fluid | Hose (Included) | | Connection Size | | Maximum Pressure psi (bar) | Assembly Part Number | Recommended Hose Inlet Kit |
|--|-----------|--|-----------------|---------------|-----------------|------------|----------------------------|----------------------|----------------------------|
| | | | ID in (mm) | Length ft (m) | Inlet | Outlet | | | |
| | XDX 10 | Air/Water/Antifreeze/Windshield Washer Fluid | 3/8 (10) | 50 (15) | 1/2 NPSM(M) | 3/8 NPT(M) | 300 (20.7) | XDL25# | 218549 |
| | | | 1/2 (13) | 35 (11) | 1/2 NPSM(M) | 1/2 NPT(M) | 300 (20.7) | XDL33# | |
| | | Oil | 1/2 (13) | 35 (11) | 1/2 NPSM(M) | 1/2 NPT(M) | 2,000 (138) | XDM33# | |
| | | Grease | 1/4 (6) | 50 (15) | 3/8 NPSM(M) | 1/4 NPT(M) | 5,000 (552) | XDH15# | |
| | XDX 20 | Air/Water/Antifreeze/Windshield Washer Fluid | 3/8 (10) | 65 (20) | 1/2 NPSM(M) | 3/8 NPT(M) | 300 (20.7) | XDL56# | 218549 |
| | | | 1/2 (13) | 50 (15) | 1/2 NPSM(M) | 1/2 NPT(M) | 300 (20.7) | XDL65# | |
| | | Oil | 1/2 (13) | 50 (15) | 1/2 NPSM(M) | 1/2 NPT(M) | 2,000 (138) | XDM65# | |
| | | Grease | 3/8 (10) | 50 (15) | 3/8 NPSM(M) | 1/4 NPT(M) | 4,800 (331) | XDH55# | |

Bare Reels

Required hose inlet kit sold separately. Fluid hose not included.

| | Reel Size | Fluid | Hose (Not Included) | | Connection Size | | Maximum Pressure psi (bar) | Part Number | Recommended Hose Inlet Kit |
|--|-----------|--|---------------------|---------------|-----------------|-------------|----------------------------|-------------|----------------------------|
| | | | ID in (mm) | Length ft (m) | Inlet | Outlet | | | |
| | XDX 10 | Air/Water/Antifreeze/Windshield Washer Fluid | 3/8 (10) | 65 (20) | 1/2 NPSM(M) | 3/8 NPSM(F) | 300 (20.7) | XDL2D# | 218549 |
| | | Oil | 1/2 (13) | 35 (11) | 1/2 NPSM(M) | 1/2 NPSM(F) | 2,000 (138) | XDM3B# | |
| | | Grease | 3/8 (10) | 35 (11) | 3/8 NPSM(M) | 3/8 NPSM(F) | 8,000 (552) | XDH1D# | |
| | XDX 20 | Air/Water/Antifreeze/Windshield Washer Fluid | 1/2 (13) | 50 (15) | 1/2 NPSM(M) | 1/2 NPSM(F) | 300 (20.7) | XDL6D# | 218549 |
| | | Oil | 1/2 (13) | 50 (15) | 1/2 NPSM(M) | 1/2 NPSM(F) | 2,000 (138) | XDM6D# | |
| | | Grease | 3/8 (10) | 50 (15) | 3/8 NPSM(M) | 3/8 NPSM(F) | 8,000 (552) | XDH5D# | |

XDX Series Hose Reels



10 / 20 / 20 XN

Ordering Information

XN Models (without Adjustable Arm)

Includes hose guide kit. **Required hose inlet kit sold separately.**

|  | Reel Size | Fluid | Hose (Included) | | Connection Size | | Maximum Pressure psi (bar) | Part Number | Hose Guide Kit (Included) | Recommended Hose Inlet Kit |
|---|-----------|---|-----------------|---------------|-----------------|------------|----------------------------|-------------|---------------------------|----------------------------|
| | | | ID in (mm) | Length ft (m) | Inlet | Outlet | | Black | | |
| | XDX 20 | Air/Water/ Antifreeze/ Windshield Washer Fluid | 3/8 (10) | 65 (20) | 1/2 NPSM(M) | 3/8 NPT(M) | 300 (20.7) | XNL56D | 15Y478 | 218549 |
| | | | 1/2 (13) | 50 (15) | 1/2 NPSM(M) | 1/2 NPT(M) | 300 (20.7) | XNL65D | | |
| | | Oil | 1/2 (13) | 50 (15) | 1/2 NPSM(M) | 1/2 NPT(M) | 2,000 (138) | XNM65D | | |
| | | Grease | 3/8 (10) | 50 (15) | 3/8 NPSM(M) | 1/4 NPT(M) | 4,800 (331) | XNH55D | | |

Accessories

Ball Stop Kits

XDX HS models include ball stop kits. Order separately if ordering a bare reel or if needed with HN models.

|  | Part Number | Description |
|--|-------------|---|
| | 222225 | For 1/4 in (6 mm) ID hose (not compatible with XD 30, 700 or 750) |
| | 218340 | For 1/4 in to 3/8 in (6 mm to 10 mm) ID hose (not for use with XD 30, 700 or 750) |
| | 218341 | 0.782 in ID used for 3/8 in and 1/2 in (10 mm and 13 mm) hose (not compatible with XD 30, 700 or 750) |
| | 237872 | 1.0 in ID used for 5/8 in (16 mm) hose |
| | 237873 | 1.123 in ID used for 3/4 in (19 mm) hose |
| | 237874 | 1.374 in ID used for 1 in (25 mm) hose |
| | 24D132 | For 3/8 in (10 mm) ID hose |
| | 24D133 | For 1/2 in (13 mm) ID hose |



Hose Inlet Kits

A hose inlet kit is required when ordering an XDX reel.

|  | Maximum Working Pressure psi (bar) | Size in (mm) | Length ft (m) | Part Number |
|---|------------------------------------|--------------|---------------|-------------|
| | 2,000 (137) | 1/2 (13) | 2 (0.6) | 218549 |
| | 4,000 (276) | 3/8 (10) | | 218550 |
| | 5,000 (345) | 1/4 (6) | | 224417 |

Mounting Channels

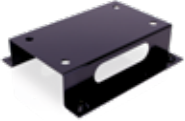
Accommodates up to six reels. Includes all parts necessary to mount on wall or overhead.

|  | Description | 1 Reel | 2 Reels | 3 Reels | 4 Reels | 5 Reels | 6 Reels |
|---|--------------------------------|--------------|---------|---------|--------------|---------|---------|
| | Enclosed Reel Mounting Channel | 24N323 | 24N324 | 24N325 | 24N326 | 24N327 | 24N328 |
|  | Open Reel Mounting Channel | 24A219 | 24A220 | 24A221 | 24A222 | 24A222 | 24A222 |
|  | I-Beam Mounting Bracket* | 204741 (x 2) | | | 204741 (x 3) | | |

*Secures mounting channel to I-beam without drilling – 2 are required for 1-3 reels, and 3 are required for 4-6 reels.



Ordering Information

Enclosure Kits for One Reel

Open mounting accommodates up to six reels. Includes all parts necessary to mount on wall or overhead. Requires Enclosed Reel Mounting Channel.

| | Reel Size | White | Metallic Blue | Red | Black | Dark Blue | Yellow | Required End-Caps (set of 2) |
|--|-----------|--------|---------------|--------|--------|-----------|--------|------------------------------|
| | XDX 10 | 24N331 | 24N332 | 24N333 | 24N334 | 24N335 | 24N336 | 24A950 |
| | XDX 20 | 24N337 | 24N339 | 24N340 | 24N341 | 24N342 | 24N343 | 24A951 |

Retrofit Adapter Kit

| | Part Number | Description |
|--|-------------|---|
| | 24A224 | Includes all parts to mount hose reel to existing 500 series mounting pattern without enclosure |
| | 24P914 | Includes all parts to convert XDX 20 hose reels to fit existing 500 series enclosures |

Valve Hanger Kit

| | Part Number | Description |
|--|-------------|--|
| | 224444 | Mounts to side of reel to allow hanging of non-metered and high-flow dispensing valves |

Self-Adhesive Identification Label Set

| | Part Number | Description |
|--|-------------|---|
| | 180698 | Set includes: 1 in x 5 in (25.4 mm x 127 mm) hose reels labels for Antifreeze, Water, SAE 5-40, SAE 10-40, SAE 20W, Hydraulic, Gear, SAE 10W, SAE 10-30, SAE 30W, Dexron, Air, Chassis, ATF |

Hose Identification Wraps

Vinyl hose wrap for easy identification of meter fluid.

| | Part Number | Description |
|--------|-------------|-------------|
| | 17S659 | Red |
| | 17S660 | Blue |
| | 17S661 | Green |
| | 17S662 | Yellow |
| 17S663 | White | |

Hose and Cord Reels

XD Series Hose Reels



30 / 30 HN

**7 Year
Warranty!**

High Capacity Reel

Used in applications requiring longer-range dispense and higher capacity than the standard XDX 10/20 series. Ideal for use on mobile service trucks, heavy construction and industrial plants.

Spring Adjustment

Increase or decrease spring tension while reel is pressurized with fluid.

Full-Flow Swivel

Maximize material flow with minimal pressure drop for faster fills to get more vehicles through your shop.

Optional Adjustable Arm

Easily change to one of seven arm positions to fit your application. Order with arm (HS models) or without (HN models).

Durable Finish

Baked-on enamel finish (four colors available) protects reel from corrosion.

Large Hose Capacity with Small Profile

Compact pedestal and spool fits into tight spaces and can accommodate 30-75 foot (9.1-22.8 meters) hose capacity for a wide variety of applications.

Typical Applications

- Heavy-duty truck dealers
- Fleet maintenance
- Mining maintenance
- Public works garage
- Construction vehicle maintenance
- Heavy-duty mobile service trucks
- Mining
- Lube trucks

Typical Fluids Handled

- Petroleum- and synthetic-based oils (motor, gear and ATF)
- Diesel fuel
- Air
- Water
- Grease
- Antifreeze
- Windshield washer fluid
- Pressure wash
- Waste oil evacuation
- Diesel exhaust fluid (DEF)

Technical Specifications

Operating Temperature Range

| | |
|--|---------------------------------|
| Air/Water/Antifreeze/ Windshield Washer Fluid | -40°F to 180°F (-40°C to 82°C) |
| Oil | -40°F to 180°F (-40°C to 82°C) |
| Grease | -40°F to 180°F (-40°C to 82°C) |
| Pressure Wash | -20°F to 225°F (-28°C to 107°C) |
| Fuel/Evacuation | -40°F to 120°F (-40°C to 49°C) |
| Diesel Exhaust Fluid (DEF) | 12°F to 140°F (-11°C to 60°C) |

Wetted Parts (Bare Reel Only)

| | |
|--|---|
| Air/Water/Antifreeze/ Windshield Washer Fluid Reels | Nickel plated carbon steel, aluminum, Buna-N rubber, UHMWPE |
| Oil | Nickel plated carbon steel, aluminum, Buna-N rubber, UHMWPE |
| Grease | Nickel plated stainless steel, Buna-N rubber, UHMWPE |
| Pressure Wash | Nickel plated stainless steel, Buna-N rubber, UHMWPE |
| Fuel/Evacuation | Nickel plated carbon steel, aluminum, Buna-N rubber, UHMWPE |
| Diesel Exhaust Fluid (DEF) | Zinc plated steel, polyurethane, steel |

| | |
|-----------------------|-----------------|
| Weight (Without Hose) | 98 lb (44.5 kg) |
| Sound Pressure Level | 85.8 dB(A) |
| Sound Power Level | 94.9 dB(A) |
| Instruction Manual | 3A0138 |

Dimensions

| | HS Models (with Adjustable Arm) | HN Models (without Arm) |
|---|---------------------------------|-------------------------|
| A | 9.0 in (229 mm) | 7.5 in (196 mm) |
| B | 21.5 in (546 mm) | 18.1 in (460 mm) |
| C | 26.0 in (659 mm) | 23.4 in (594 mm) |
| D | 22.1 in (562 mm) | 20.0 in (508 mm) |
| E | 23.1 in (588 mm) | 21.0 in (533 mm) |
| F | 27.6 in (701 mm) | 25.2 in (640 mm) |

HS Models

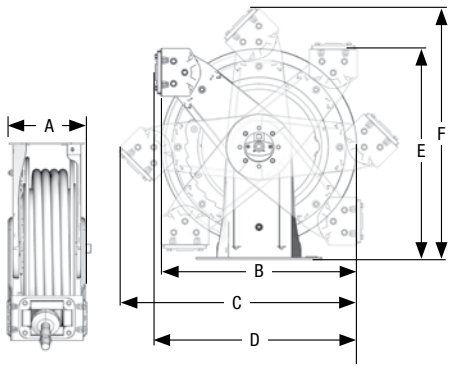

HN Models

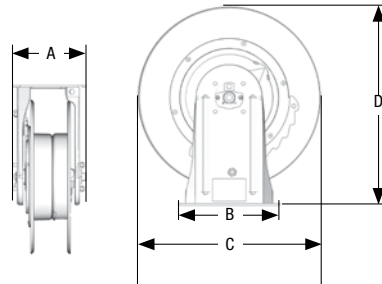

Typical Mounting Configurations

Overhead Mount

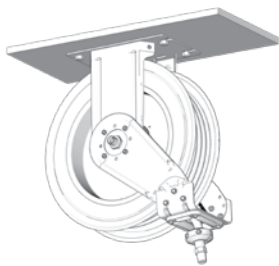

Wall Mount

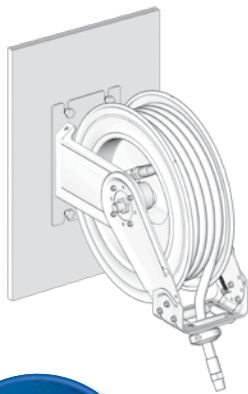

Bench/ Truck Mount

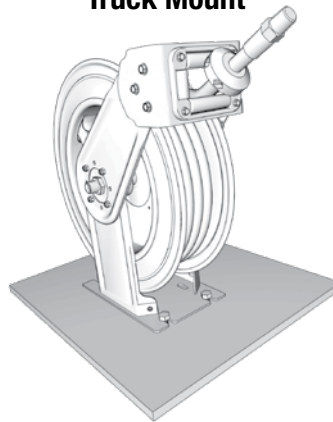

Truck Mount with Remote Mounted Roller Guide

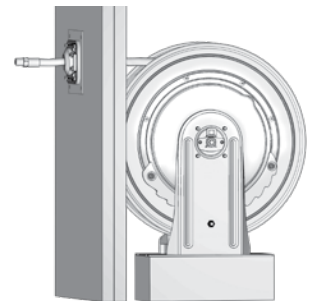

Metallic Blue (B)
Standard In-Stock Color



**Available in
4 Colors**
Consult factory for
lead times.

Yellow (F)



White (A)



Desert Sand (G)



Hose and Cord Reels

XD Series Hose Reels



30 / 30 HN

Ordering Information

XD 30 Reel Assembly Ordering Guide

XD Series reels are available in four colors. Use the chart below to determine the correct part number to order. The last character of each part number indicates the hose reel color.

| Reel Color | Identifier |
|---------------|------------|
| White | A |
| Metallic Blue | B |
| Yellow | F |
| Desert Sand* | G |

*Desert Sand not available on HN Models.

Order Example:

Arm in overhead mount position, XD 30, oil, 3/4 in ID hose, 50 ft hose length

- Select your reel position:** HSMD5#
- Select your reel color:** Metallic Blue = "B"
(from Reel Assembly Ordering Guide – opposite)

Order Part Number:

HSMD5B



HS Models (with Adjustable Arm)

Reel Assemblies

Assembly includes hose, ball stop kit and roller guide. **Required hose inlet kit sold separately.**

| Fluid | Hose (Included) | | Connection Size | | Maximum Pressure psi (bar) | Reel, Hose and Ball Stop Assembly Part Number | Recommended Hose Inlet Kit |
|--|-----------------|---------------|-----------------|--------------|----------------------------|---|----------------------------|
| | ID in (mm) | Length ft (m) | Inlet | Outlet | | | |
| Air/Water/Antifreeze/Windshield Washer Fluid | 1/2 (13) | 75 (23) | 1/2 NPSM(M) | 1/2 NPT(M) | 300 (20.7) | HSLC8# | 218549 |
| | 3/4 (19) | 50 (15) | 3/4 NPSM(M) | 3/4 NPT(M) | 300 (20.7) | HSLD5# | 24E284 |
| Oil | 1/2 (13) | 75 (23) | 1/2 NPSM(M) | 1/2 NPT(M) | 1,500 (103) | HSMC8# | 218549 |
| | 3/4 (19) | 50 (15) | 3/4 NPSM(M) | 3/4 NPT(M) | 1,250 (86) | HSM5# | 24E284 |
| Grease | 1/2 (13) | 50 (15) | 1/2 NPSM(M) | 1/2 NPT(M) | 5,000 (345) | HSHC5# | 24E283 |
| | 3/8 (10) | 75 (23) | 1/2 NPSM(M) | 3/8 NPT(F) | 5,000 (345) | HSHB7# | 24E283 |
| Pressure Wash | 3/8 (10) | 75 (23) | 1/2 NPSM(M) | 3/8 NPT(M) | 4,000 (276) | HSPB8# | 24E283 |
| | 1/2 (13) | 50 (15) | 1/2 NPSM(M) | 1/2 NPT(M) | 4,500 (310) | HSPC5# | 24E283 |
| Fuel/Oil Evacuation | 1 (13) | 30 (9) | 3/4 NPSM(M) | 1 NPT(M) | 125 (8.6) | HSLE3# | 24E285 |
| DEF | 3/4 (19) | 50 (15) | 3/4 BSPP(M) | 3/4 BSPP ORB | 50 (3.4) | HSDD5# | 24W250 (BSPP) |

Bare Reels

Required hose inlet kit sold separately.

| Fluid | Hose (Not Included) | | Connection Size | | Maximum Pressure psi (bar) | Part Number | Recommended Hose Inlet Kit |
|---------------|---------------------|---------------|-----------------|----------------|----------------------------|-------------|----------------------------|
| | ID in (mm) | Length ft (m) | Inlet in (mm) | Outlet in (mm) | | | |
| Oil | 1/2 (13) | 75 (23) | 1/2 (13) (m) | 1/2 (13) (m) | 2,000 (138) | HSMCF# | 218549 |
| | 3/4 (19) | 50 (15) | 3/4 (19) (m) | 3/4 (19) (m) | 2,000 (138) | HSMDD# | 24E284 |
| Grease | 1/2 (13) | 50 (15) | 1/2 (13) (m) | 1/2 (13) (m) | 5,000 (345) | HSHCD# | 24E283 |
| Pressure Wash | 3/8 (10) | 75 (23) | 1/2 (13) (m) | 3/8 (10) (m) | 4,000 (276) | HSHFF# | 24E283 |
| DEF | 3/4 (19) | 50 (15) | 3/4 (19) (m) | 3/4 (19) ORB | 50 (3.4) | HSDDD# | 24W250 (BSPP) |

Hose and Cord Reels

Ordering Information

HN Models (without Adjustable Arm)

Reels with Hose

Required hose inlet kit sold separately.



| Fluid | Hose (Included) | | Connection Size | | Maximum Pressure psi (bar) | Reel and Hose Assembly Part Number | Recommended Hose Inlet Kit |
|--|-----------------|---------------|-----------------|------------|----------------------------|------------------------------------|----------------------------|
| | ID in (mm) | Length ft (m) | Inlet | Outlet | | | |
| Air/Water/Antifreeze/ Windshield Washer Fluid | 1/2 (13) | 75 (23) | 1/2 NPSM(M) | 1/2 NPT(M) | 300 (20.7) | HNLC8# | 218549 |
| | 3/4 (19) | 50 (15) | 3/4 NPSM(M) | 3/4 NPT(M) | 300 (20.7) | HNLD5# | 24E284 |
| Oil | 1/2 (13) | 75 (23) | 1/2 NPSM(M) | 1/2 NPT(M) | 1,500 (103) | HNMC8# | 218549 |
| | 3/4 (19) | 50 (15) | 3/4 NPSM(M) | 3/4 NPT(M) | 1,250 (86) | HNMD5# | 24E284 |
| Grease | 1/2 (13) | 50 (15) | 1/2 NPSM(M) | 1/2 NPT(M) | 5,000 (345) | HNHC5# | 24E283 |
| | 3/8 (10) | 75 (23) | 1/2 NPSM(M) | 3/8 NPT(F) | 5,000 (345) | HNHB7# | 24E283 |
| Pressure Wash | 3/8 (10) | 75 (23) | 1/2 NPSM(M) | 3/8 NPT(M) | 4,000 (276) | HNPB8# | 24E283 |
| | 1/2 (13) | 50 (15) | 1/2 NPSM(M) | 1/2 NPT(M) | 4,500 (310) | HNPC5# | 24E283 |
| Fuel/Oil Evacuation | 1 (13) | 30 (9) | 3/4 NPSM(M) | 1 NPT(M) | 125 (8.6) | HNLE3# | 24E285 |

Bare Reels

Required hose inlet kit sold separately.



| Fluid | Hose (Not Included) | | Connection Size | | Maximum Pressure psi (bar) | Part Number | Recommended Hose Inlet Kit |
|---------------|---------------------|---------------|-----------------|----------------|----------------------------|-------------|----------------------------|
| | ID in (mm) | Length ft (m) | Inlet in (mm) | Outlet in (mm) | | | |
| Oil | 3/4 (19) | 50 (15) | 3/4 (19) (m) | 3/4 (19) (m) | 2,000 (138) | HNMD5# | 24E284 |
| Grease | 1/2 (13) | 50 (15) | 1/2 (13) (m) | 1/2 (13) (m) | 5,000 (345) | HNHC5# | 24E283 |
| Pressure Wash | 3/8 (10) | 75 (23) | 1/2 (13) (m) | 3/8 (10) (m) | 4,000 (276) | HNHB7# | 24E283 |

Ball Stop Kits

XD HS models include ball stop kits. Order separately if ordering a bare reel or if needed with HN models.



| Part Number | Description |
|-------------|---|
| 222225 | For 1/4 in (6 mm) ID hose (not compatible with XD 30, 700 or 750) |
| 218340 | For 1/4-3/8 in (6-10 mm) ID hose (not for use with XD 30, 700 or 750) |
| 218341 | 0.782 in ID used for 3/8 in and 1/2 in (10 mm and 13 mm) hose (not compatible with XD 30, 700 or 750) |
| 237872 | 1.0 in ID used for 5/8 in (16 mm) hose |
| 237873 | 1.123 in ID used for 3/4 in (19 mm) hose |
| 237874 | 1.374 in ID used for 1 in (25 mm) hose |
| 24D132 | For 3/8 in (10 mm) ID hose |
| 24D133 | For 1/2 in (13 mm) ID hose |



Ordering Information

Hose Inlet Kits

A hose inlet kit is required when ordering an XD reel.

|  | Part Number | Description |
|---|-------------|---|
| | 218549 | 1/2 in (13 mm) hose inlet kit for air/water and oil. 2,000 psi (137 bar), 1/2 in NPT hose inlet ID, 24 in (610 mm) long |
| | 24E284 | 3/4 in (19 mm) hose inlet kit for air/water and oil. 1,250 psi (86 bar), 3/4 in NPT hose inlet ID, 24 in (610 mm) long |
| | 24E283 | 1/2 in (13 mm) hose inlet kit for grease or pressure wash. 5,000 psi (345 bar), 1/2 in NPT hose inlet ID, 24 in (610 mm) long |
| | 24E285 | 1/2 in (13 mm) hose inlet kit for fuel. 125 psi (8.6 bar), 1/4 in NPT hose inlet ID, 24 in (610 mm) long |
| | 24W250 | 2 ft DEF inlet hose kit for XD 30 reels. 3/4 in BSPP(F) x cut end and 90° elbow |
| | 24W251 | 6 ft DEF inlet hose kit for XD 30 reels. 3/4 in BSPP(F) x cut end and 90° elbow |
| | 124875 | 2 ft DEF hose, 3/4 in BSPP(M) x cut end (inlet hose) |
| | 124581 | 6 ft DEF hose, 3/4 in BSPP(M) x cut end (inlet hose) |

Valve Hanger Kit

|  | Part Number | Description |
|---|-------------|--|
| | 224444 | Mounts to side of reel to allow hanging of non-metered and high-flow dispensing valves |

Self-Adhesive Identification Label Set

|  | Part Number | Description |
|---|-------------|---|
| | 180698 | Set includes: 1 in x 5 in (25.4 mm x 127 mm) hose reels labels for Antifreeze, Water, SAE 5-40, SAE 10-40, SAE 20W, Hydraulic, Gear, SAE 10W, SAE 10-30, SAE 30W, Dexron, Air, Chassis, ATF |

Hose Identification Wraps

Vinyl hose wrap for easy identification of meter fluid.

|  | Part Number | Description |
|---|-------------|-------------|
| | 17S659 | Red |
| | 17S660 | Blue |
| | 17S661 | Green |
| | 17S662 | Yellow |
| | 17S663 | White |



**7 Year
Warranty!**

Built-In Toughness

Engineered to take a beating and still reliably perform in harsh environments so it's ready when you need it. Choose from more colors, thread types and hoses or choose the bare reel so you can customize it with your hose. You get a professional look, easier fit and better-performing equipment.

Extensive Hose Offering

Standard models come complete with factory-installed hoses on the reel. Large selection of optional reels to fit various applications.

Full-Flow Swivel

Maximize material flow with minimal pressure drop for faster fills to get more vehicles through your shop.

Rugged and Durable Body

Heavy-duty welded spool and ribbed frame for extra strength and toughness over the long haul.

Meets Worldwide Needs

Built standard with 90° elbow with NPT, BSPP or BSPT threads. 1-1/2 in models also include 2 in Victaulic™*-style groove. Accessories attach without the need for adapters.

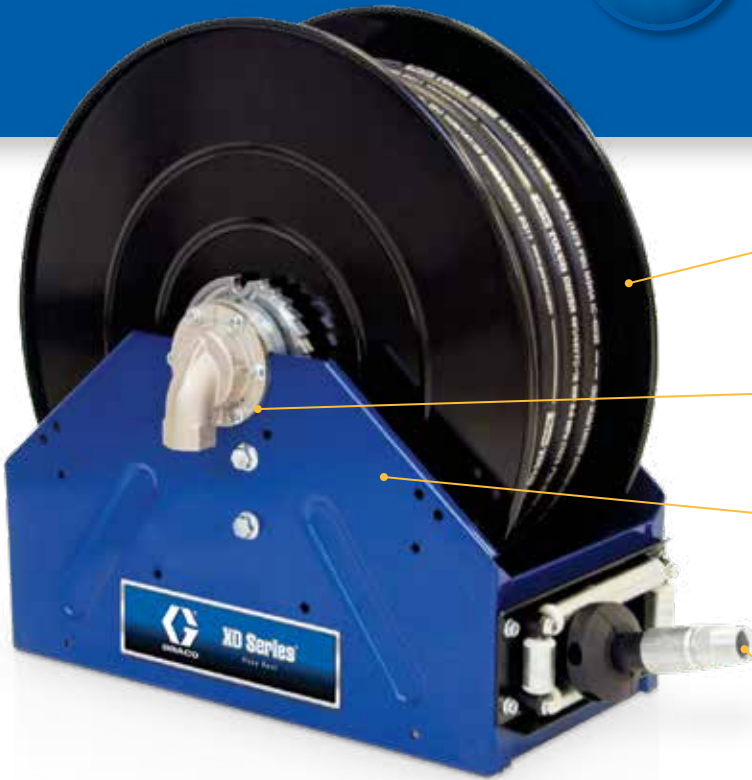

Typical Applications

- Heavy-duty truck dealers
- Fleet maintenance
- Mining maintenance
- Public works garages
- Construction vehicle maintenance
- Heavy-duty mobile service trucks
- Agriculture
- Lube trucks

Typical Fluids Handled

- Petroleum- and synthetic-based oils (motor, gear and ATF)
- Diesel fuel
- Air
- Water
- Antifreeze
- Waste oil evacuation

Technical Specifications

| | |
|-------------------------------------|--|
| Operating Temperature Range | |
| Oil Reels – 1 inch | -20°F to 180°F (-28°C to 82°C) |
| All Other Reels | -40°F to 180°F (-40°C to 82°C) |
| Wetted Parts | Carbon steel, nickel plated cast iron, Buna-N rubber, FKM UHMWPE |
| Maximum Recommended Mounting Height | 15 ft (4.6 m) |
| Sound Pressure Level | 77.6 dB(A) |
| Sound Power Level | 86.8 dB(A) |

*Victaulic is a trademark of Victaulic Company of America.

How to Select an XD 40/50 Hose Reel

2 Ways to Order!

Option 1 – Reel with Hose

(Pages 246-247)

All models include the hose, hose guide and ball stop kit.



Option 2 – Bare Reel

(Pages 246-247)

Bare reel models do not include hose and ball stop kit.



Choose Your Accessories (Pages 248)

Hose Inlet Kit

A hose inlet is required for installation. They are appropriately sized for the hose reels based on type of fluid, hose size and pressure.



Support Arm

For additional support, add arm brackets to the reel. Required for overhead mounting applications.



Mounting Kit

Overhead mounting options available for XD 40 reels.



Hose Kit

Large selection of hoses appropriately sized for the hose reels based on type of fluid, hose size and pressure.



Hose Inlet Kit

A hose inlet is required for installation. They are appropriately sized for the hose reels based on type of fluid, hose size and pressure.



Ball Stop Kit

When the ball stop comes in contact with the hose guide, the hose is prohibited from rewinding.



Support Arm

For additional support, add arm brackets to the reel. Required for overhead mounting applications.



Mounting Kit

Overhead mounting options available for XD 40 reels.



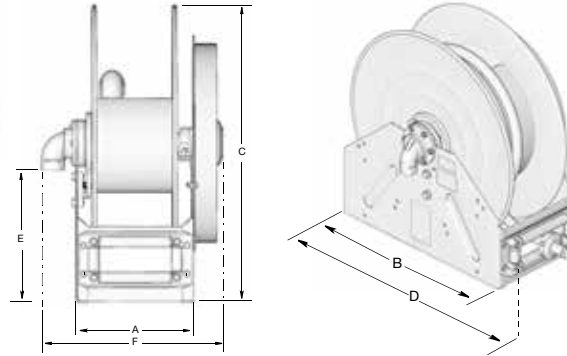

Dimensions

| Model | Inlet/Outlet Size NPT(F) | Dimensions in (mm)* | | | | | |
|-------------------|-----------------------------|---------------------|------------|-------------|------------|-------------|-------------|
| | | A | B | C | D | E | F |
| XD 4010 – Model 1 | 1 in/1 in | 11.83 (300) | 24 (610) | 26.13 (664) | 26.4 (671) | 10.91 (277) | 16.54 (420) |
| XD 4010 – Model 2 | 1 in/1 in | 11.83 (300) | 24 (610) | 26.13 (664) | 26.4 (671) | 10.91 (277) | 17.47 (444) |
| XD 5010 | 1 in/1 in | 11.83 (300) | 28.5 (724) | 30.13 (765) | 29.4 (747) | 10.91 (277) | 17.4 (444) |
| XD 5015 | 1-1/2 in/ 1-1/2 in | 11.83 (300) | 28.5 (724) | 30.13 (765) | 29.4 (747) | 10.91 (277) | 18.24 (463) |

*For complete list of dimensions, see Graco product manual 3A2990.

Typical Mounting Configurations

Truck-Bed or Bench Mount

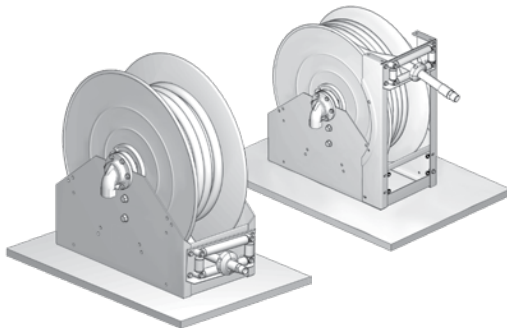

Overhead Mount (XD 40 only)

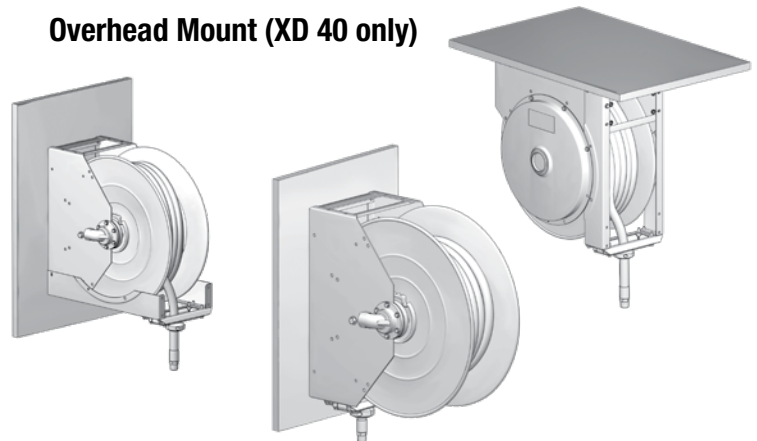

Available in
3 Colors
Consult factory for
lead times.

Standard In-Stock Color:
Metallic Blue



XD Series Hose Reels

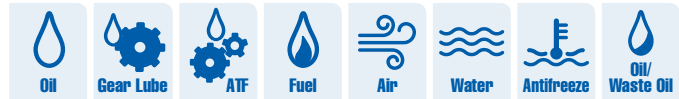

40 / 50

Ordering Information

XD 40 Reels with Hose

Includes hose, ball stop kit and hose guide. *Required hose inlet kit sold separately.*

| Reel Size | Fluid | Hose | | Connection Size | | Maximum Pressure psi (bar) | Part Number by Reel Color | | | Hose Inlet Kit (Order Separately) | Truck/Bench Mount Only | |
|-----------|----------------------|------------|---------------|-----------------|---------------|----------------------------|---------------------------|--------|--------|-----------------------------------|------------------------|--|
| | | ID in (mm) | Length ft (m) | Inlet NPT(F) | Outlet NPT(M) | | Metallic Blue | Yellow | White | | | |
| XD 4010 | Air/Water | 1/2 (13) | 100 (30) | 1 | 1/2 | 300 (21) | 24P327 | 24P328 | 24P329 | 24R111 | | |
| | | 3/4 (19) | 75 (23) | 1 | 3/4 | 300 (21) | 24P330 | 24P331 | 24P332 | | | |
| | | 3/4 (19) | 100 (30) | 1 | 3/4 | 300 (21) | 24P333 | 24P334 | 24P335 | | | |
| | | 1 (25) | 50 (15) | 1 | 1 | 300 (21) | 24P336 | 24P337 | 24P338 | | | |
| | Antifreeze | 3/4 (19) | 100 (30) | 1 | 3/4 | 300 (21) | 24P984 | 24P985 | 24P986 | | | |
| | Oil | 1/2 (13) | 100 (30) | 1 | 1/2 | 2,000 (138) | 24P339 | 24P340 | 24P341 | | | |
| | | 3/4 (19) | 75 (23) | 1 | 3/4 | 1,500 (103) | 24P342 | 24P343 | 24P344 | | • | |
| | | 3/4 (19) | 75 (23) | 1 | 3/4 | 1,500 (103) | 24R857 | 24R859 | 24R860 | | | |
| | | 3/4 (19) | 100 (30) | 1 | 3/4 | 1,500 (103) | 24P345 | 24P346 | 24P347 | | | |
| | | 1 (25) | 50 (15) | 1 | 1 | 1,275 (88) | 24P348 | 24P349 | 24P350 | | • | |
| | 1 (25) | 50 (15) | 1 | 1 | 1,275 (88) | 24R861 | 24R862 | 24R863 | | | | |
| | Waste Oil Evacuation | 1 (25) | 50 (15) | 1 | 1 | 250 (17) | 24P351 | 24P352 | 24P353 | | 24R112 | |
| | Diesel Fuel | 1 (25) | 50 (15) | 1 | 1 | 250 (17) | 24P354 | 24P355 | 24P356 | | 24R115 | |

XD 40 Bare Reels

| Reel Size | Fluid | Hose Length Capacity (in x ft (m)) | | | Connection Size | | Maximum Pressure psi (bar) | Part Number by Reel Color | | | Hose Inlet Kit (order separately) | Truck/Bench Mount Only | |
|-----------|----------------------|------------------------------------|----------|---------|-----------------|---------------|----------------------------|---------------------------|--------|--------|-----------------------------------|------------------------|--|
| | | 1/2 | 3/4 | 1 | Inlet NPT(F) | Outlet NPT(F) | | Metallic Blue | Yellow | White | | | |
| XD 4010 | Air/Water | 100 (30) | 75 (23) | 50 (15) | 1 | 1 | 600 (41) | 24P313 | 24P315 | 24P316 | 24R111 | | |
| | | – | 100 (30) | – | 1 | 1 | 600 (41) | 24P317 | 24P318 | 24P319 | | | |
| | Antifreeze | – | 100 (30) | 50 (15) | 1 | 1 | 600 (41) | 26A140 | 26A141 | 26A142 | | | |
| | Oil | – | 75 (23) | 50 (15) | 1 | 1 | 2,000 (138) | 24P320 | 24P322 | 24P323 | | • | |
| | | – | 75 (23) | 50 (15) | 1 | 1 | 2,000 (138) | 24R854 | 24R855 | 24R856 | | | |
| | | 100 (30) | 100 (30) | – | 1 | 1 | 2,000 (138) | 24P324 | 24P325 | 24P326 | | | |
| | Waste Oil Evacuation | – | – | 75 (23) | 1 | 1 | 600 (41) | 24P317 | 24P318 | 24P319 | | 24R112 | |
| | Diesel Fuel | – | – | 50 (15) | 1 | 1 | 600 (41) | 24P317 | 24P318 | 24P319 | | 24R115 | |

Remember to Order!

| | | | |
|--|--|---|--|
|  <p>Ball Stop Kit See page 248</p> |  <p>Support Arm See page 248</p> |  <p>Hose See page 260-261</p> |  <p>Hose Inlet See page 248</p> |
|--|--|---|--|

Hose and Cord Reels



Ordering Information

XD 50 Reels with Hose

Includes hose, ball stop kit and hose guide. *Required hose inlet kit sold separately.*

| Reel Size | Fluid | Hose | | Connection Size | | Maximum Pressure psi (bar) | Part Number by Reel Color | | | Hose Inlet Kit (Order Separately) |
|-------------|------------|----------------------|---------------|-----------------|---------------|----------------------------|---------------------------|--------|--------|-----------------------------------|
| | | ID in (mm) | Length ft (m) | Inlet NPT(F) | Outlet NPT(M) | | Metallic Blue | Yellow | White | |
| | | | | | | | | | | |
| XD 5010 | Air/Water | 1 (25) | 75 (23) | 1 | 1 | 300 (21) | 24P470 | 24P471 | 24P472 | 24R111 |
| | | 1 (25) | 100 (30) | 1 | 1 | 300 (21) | 24P473 | 24P474 | 24P475 | |
| | Antifreeze | 1 (25) | 100 (30) | 1 | 1 | 300 (21) | 24P987 | 24P988 | 24P989 | |
| | Oil | 1 (25) | 75 (23) | 1 | 1 | 1,275 (88) | 24P476 | 24P477 | 24P478 | 24R115 |
| | | 1 (25) | 100 (30) | 1 | 1 | 250 (17) | 24P485 | 24P486 | 24P487 | |
| | XD 5015** | Waste Oil Evacuation | 1-1/4 (32) | 35 (11) | 1-1/2 | 1-1/4 | 200 (14) | 24P479 | 24P480 | 24P481 |
| 1-1/4 (32) | | | 50 (15) | 1-1/2 | 1-1/4 | 200 (14) | 24P482 | 24P483 | 24P484 | |
| Diesel Fuel | | 1-1/4 (32) | 35 (11) | 1-1/2 | 1-1/4 | 250 (17) | 24P491 | 24P492 | 24P493 | 24R117 |
| | | 1-1/4 (32) | 50 (15) | 1-1/2 | 1-1/4 | 250 (17) | 24P494 | 24P495 | 24P496 | |
| | | 1-1/2 (38) | 50 (15) | 1-1/2 | 1-1/2 | 150 (10) | 24P497 | 24P498 | 24P499 | |
| | | 1-1/2 (38) | 50 (15) | 1-1/2 | 1-1/2 | 150 (10) | 24P497 | 24P498 | 24P499 | |





**Standard 2 inch Vitaulic™ -style groove on inlet.

XD 50 Bare Reels

| Reel Size | Fluid | Hose Length Capacity (in x ft (m)) | | | Connection Size | | Maximum Pressure psi (bar) | Part Number by Reel Color | | | Hose Inlet Kit (order separately) |
|-----------|----------------------|------------------------------------|---------|---------|-----------------|---------------|----------------------------|---------------------------|--------|--------|-----------------------------------|
| | | 1 | 1-1/4 | 1-1/2 | Inlet NPT(F) | Outlet NPT(F) | | Metallic Blue | Yellow | White | |
| | | | | | | | | | | | |
| XD 5010 | Air/Water | 100 (30) | - | - | 1 | 1 | 600 (41) | 24P455 | 24P456 | 24P457 | 24R111 |
| | Antifreeze | 100 (30) | - | - | 1 | 1 | 600 (41) | 26A143 | 26A144 | 26A145 | |
| | Oil | 75 (23) | - | - | 1 | 1 | 2,000 (138) | 24P458 | 24P459 | 24P460 | |
| | Diesel Fuel | 100 (30) | - | - | 1 | 1 | 600 (41) | 24P455 | 24P456 | 24P457 | 24R115 |
| | | 75 (23) | - | - | 1 | 1 | 600 (41) | 24P464 | 24P465 | 24P466 | |
| XD 5015** | Waste Oil Evacuation | - | 50 (15) | - | 1-1/2 | 1-1/2 | 600 (41) | 24P461 | 24P462 | 24P463 | - |
| | Diesel Fuel | - | 50 (15) | - | 1-1/2 | 1-1/2 | 600 (41) | 24P461 | 24P462 | 24P463 | 24R117 |
| | | - | 50 (15) | 50 (15) | 1-1/2 | 1-1/2 | 600 (41) | 24P467 | 24P468 | 24P469 | |

**Standard 2 inch Vitaulic™ -style groove on inlet.

Remember to Order!

| | | | |
|---|---|--|---|
|  Ball Stop Kit See page 248 |  Support Arm See page 248 |  Hose See page 260-261 |  Hose Inlet See page 248 |
|---|---|--|---|

XD Series Hose Reel Accessories

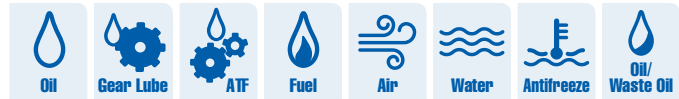

40 / 50

Ordering Information

Ball Stop Kits

|  | Part Number | Description |
|---|-------------|--|
| | 237873 | Ball stop kit used for 3/4 in (19 mm) hose |
| | 237874 | Ball stop kit used for 1 in (25 mm) hose |
| | 24R060 | Ball stop kit used for a 1-1/4 in (32 mm) hose |
| | 24R061 | Ball stop kit used for a 1-1/2 in (38 mm) hose |

Hose Guides

|  | Part Number | Description |
|---|-------------|---|
| | 24R072 | Roller guide kit with bracket for XD 40 and XD 60 |
| | 24R074 | Roller guide kit with bracket for XD 50 |

Support Arm Kits

|  | Part Number | Description |
|---|-------------|---------------------------|
| | 24R076 | Support arm kit for XD 40 |
| | 24R077 | Support arm kit for XD 50 |

Mounting Kit

|  | Part Number | Description |
|---|-------------|--|
| | 237932 | Overhead or wall mounting kit for XD 40. Includes all parts needed for overhead mounting one reel. |

Hose Inlet Kits

|  | Part Number | Description |
|---|-------------|---|
| | 24R111 | 1 in (25 mm) hose inlet kit for air/water and oil. 1,275 psi (88 bar), 1 in NPT hose inlet ID, 28 in (710 mm) long |
| | 24R112 | 1 in (25 mm) hose inlet kit for waste oil evacuation. 250 psi (17 bar), 1 in NPT hose inlet ID, 28 in (710 mm) long |
| | 24R115 | 1 in (25 mm) hose inlet kit for diesel fuel. 250 psi (17 bar), 1 in NPT hose inlet ID, 28 in (710 mm) long |
| | 24R117 | 1-1/2 in (38 mm) hose inlet kit for diesel fuel. 150 psi (10 bar), 1.5 in NPT hose inlet ID, 28 in (710 mm) long |

Self-Adhesive Identification Label Set

|  | Part Number | Description |
|---|-------------|---|
| | 180698 | Set includes: 1 in x 5 in (25.4 mm x 127 mm) hose reels labels for Antifreeze, Water, SAE 5-40, SAE 10-40, SAE 20W, Hydraulic, Gear, SAE 10W, SAE 10-30, SAE 30W, Dexron, Air, Chassis, ATF |

Hose Identification Wraps

Vinyl hose wrap for easy identification of meter fluid

|  | Part Number | Description |
|---|-------------|-------------|
| | 17S659 | Red |
| | 17S660 | Blue |
| | 17S661 | Green |
| | 17S662 | Yellow |
| | 17S663 | White |

Hose and Cord Reels

XD Series Powered Bare Hose Reels



60 / 70 / 80

**7 Year
Warranty!**

Safe, Versatile Powered Hose Reels

We like to think of the XD motor rewind reels as super-powered. The innovative design is packed with features to help you work safer, smarter and faster. We demand extensive product testing, often exceeding industry standards to ensure you get the best product on the market.

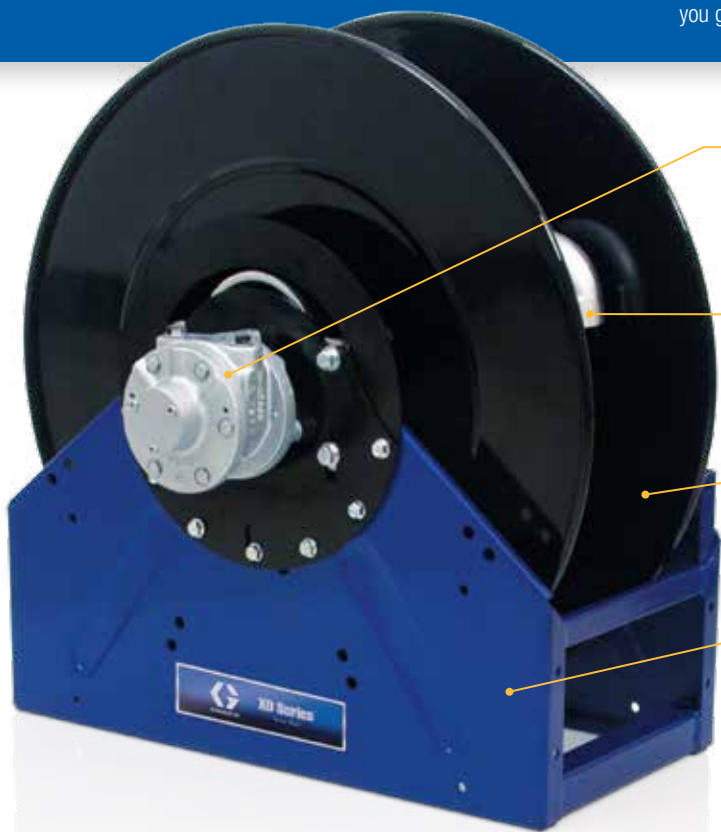

Safe, Reliable Direct Drive and Gear Motors

Drive unit is clean and lubricated for life. No need to worry about greasy, exposed drive chains that need maintenance and can be dangerous to operators.

Easy System Integration

Easily change the inlet and motor direction to give you the option of a right- or left-hand flow orientation.

Heavy-duty Welded Spool

Built to handle the weight of heavy hoses. Designed to surround and protect the drive unit from the elements to promote longer-lasting, safer operation.

Rugged and Durable Body

Heavy-duty one piece welded frame is engineered to flex under extreme operating conditions and is stronger than bolted frames that can loosen with use. Individually painted and powder-coated components have superior corrosion resistance over assembled and painted products.

Typical Applications

- Heavy-duty truck dealers
- Fleet maintenance
- Mining maintenance
- Public works garages
- Construction vehicle maintenance
- Heavy-duty mobile service trucks
- Agriculture
- Lube trucks

Typical Fluids Handled

- Petroleum- and synthetic-based oils (motor, gear and ATF)
- Diesel fuel
- Air
- Water
- Grease
- Waste oil evacuation

Technical Specifications

| | |
|--|---|
| Operating Temperature Range | |
| Motorless Reels | -40°F to 180°F (-40°C to 82°C) |
| Air/Water Applications | -40°F to 180°F (-40°C to 82°C) |
| Waste Oil Evacuation Applications | -40°F to 180°F (-40°C to 82°C) |
| Oil Applications | -40°F to 180°F (-40°C to 82°C) |
| Grease Applications | 0°F to 180°F (-18°C to 82°C) |
| Diesel Fuel Applications | -40°F to 140°F (-40°C to 60°C) |
| Wetted Parts | Nickel plated cast iron, cast iron, Buna-N rubber, polyethylene |
| Electric and Hydraulic Motors Sound Pressure Level | <80 dB(A) |
| Pneumatic Motors Sound Pressure Level | 84.6 dB(A) |
| Pneumatic Motors Sound Power Level | 89.9 dB(A) |
| Instruction Manual | 332630 |



XD Series Bare Hose Reels

60 / 70 / 80

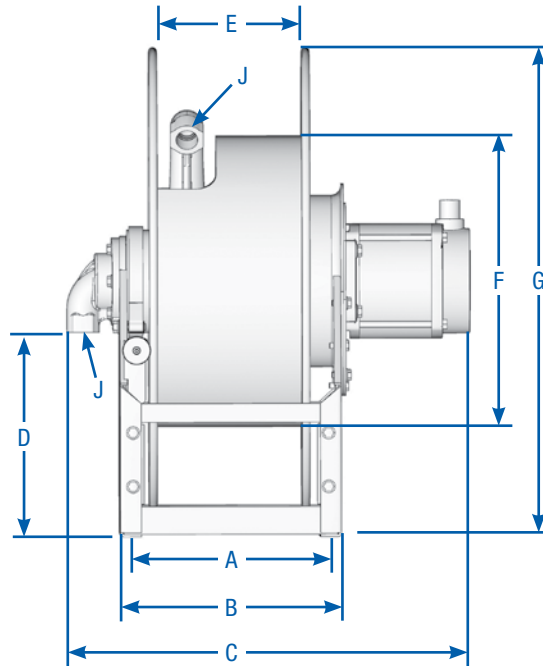

Dimensions

Reference dimension "D" for specific motor type

| Model | Inlet/Outlet Size (J) NPT(F) | Dimensions in (mm) | | | | | | | | |
|---------|------------------------------|--------------------|------------|------------|------------|------------|------------|-----------|------------|------------|
| | | A (Mounting Holes) | B | C | | | D | E | F | G |
| | | | | Pneumatic | Hydraulic | Electric | | | | |
| XD 6010 | 1 in/1 in | 10.45 (256) | 11.8 (300) | 20.4 (519) | 15.7 (400) | 21.6 (547) | 10.9 (277) | 7.8 (198) | 15.5 (394) | 26.1 (663) |
| XD 7010 | 1 in/1 in | 12.95 (329) | 14.3 (363) | 22.9 (583) | 18.2 (463) | 24.1 (611) | 10.9 (277) | 10 (254) | 10 (254) | 26.1 (663) |
| XD 7015 | 1-1/2 in/1-1/2 in | 12.95 (329) | 14.3 (363) | 23.7 (603) | 19 (483) | 24.8 (631) | 10.9 (277) | 10 (254) | 10 (254) | 26.1 (663) |
| XD 7020 | 2 in/2 in | 12.95 (329) | 14.3 (363) | 24.1 (613) | 19.4 (493) | 25.2 (641) | 10.2 (259) | 10 (254) | 10 (254) | 26.1 (663) |
| XD 8010 | 1 in/1 in | 20.68 (525) | 22.1 (561) | 30.7 (779) | 26 (659) | 31.8 (807) | 13.4 (340) | 18 (457) | 15.5 (394) | 30.1 (765) |
| XD 8015 | 1-1/2 in/1-1/2 in | 20.68 (525) | 22.1 (561) | 31.4 (799) | 26.7 (679) | 32.5 (827) | 13.4 (340) | 18 (457) | 15.5 (394) | 30.1 (765) |
| XD 8020 | 2 in/2 in | 20.68 (525) | 22.1 (561) | 31.9 (809) | 27.1 (689) | 33 (837) | 12.7 (323) | 18 (457) | 15.5 (394) | 30.1 (765) |

Typical Mounting Configurations

Bench/Trunk Mount

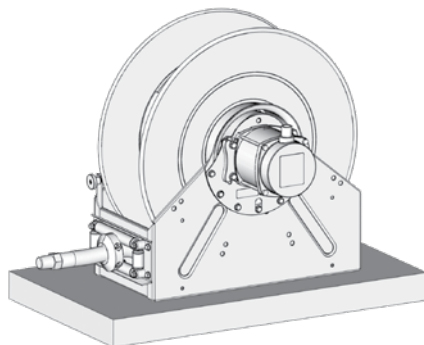

Truck Mount with Remote Mounted Roller Guide

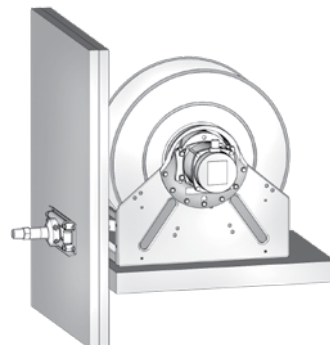

Hose and Cord Reels

How to Select an XD Powered Bare Hose Reel

A Complete Family of Motor Rewind Hose Reels

The innovative design of the XD reel family is packed with features to help you work safer, smarter and faster. Direct-drive motor options include hydraulic, pneumatic and electric for air, water, oil, grease, fuel dispense and waste oil evacuation applications. Use this selection chart to configure the XD reel to suit your needs.

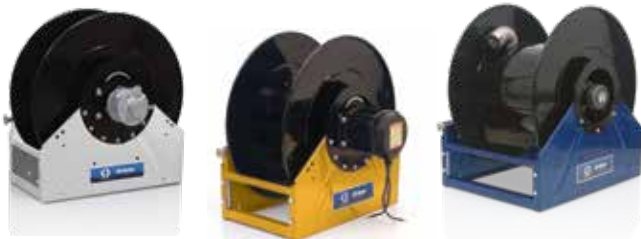

A

Specify the Hose Fluid Type and Capacity

Determine your fluid type and capacity before selecting your reel.

REQUIRED

| Fluid Type | Hose ID in (mm) | Hose Length ft (m) |
|--|-------------------------------------|-----------------------------------|
| <input type="checkbox"/> Air/Water | <input type="checkbox"/> 1/2 (13) | <input type="checkbox"/> 50 (15) |
| <input type="checkbox"/> Antifreeze | <input type="checkbox"/> 1 (25) | <input type="checkbox"/> 75 (23) |
| <input type="checkbox"/> Petroleum- and Synthetic-Based Oils | <input type="checkbox"/> 1-1/2 (38) | <input type="checkbox"/> 100 (30) |
| <input type="checkbox"/> Waste Oil | <input type="checkbox"/> 2 (51) | <input type="checkbox"/> 150 (46) |
| <input type="checkbox"/> Diesel Fuel | | |

B

Choose Your Reel Size

- XD 60 XD 70 XD 80

C

Choose Your Reel Color

Select from Blue, Yellow or White.

- Blue Yellow White

D

Select Your Drive Type and Frame

Reels can be ordered with a motor or without. If you choose a model without a motor, you must purchase the motor separately.

REQUIRED

- Order Reel with Motor Included (Pages 254-256)
- Order Reel and Motor Separately (Page 257)
 - Pneumatic Motor
 - Hydraulic Motor
 - Electric Motor
 - 12 VDC, 1/2 HP 24 VDC, 2/3 HP
 - 12 VDC, 2/3 HP 115 VAC, 0.40 HP
 - 24 VDC, 1/2 HP

E

Choose Your Controls (Pages 258)

REQUIRED

- Pneumatic Motor**
 - Pneumatic 2-position, 3-way valve
- Hydraulic Motor**
 - 12 VDC electric control of hydraulic motor, 3-position, 4-way valve
 - 12 VDC electric control of hydraulic motor with switch, 3-position, 4-way valve
 - 24 VDC electric control of hydraulic motor, 3-position, 4-way valve
 - 24 VDC electric control of hydraulic motor with switch, 3-position, 4-way valve
- Electric Motor**
 - Hazardous location on/off button
 - 12 VDC intermittent-duty solenoid
 - 24 VDC intermittent-duty solenoid
 - Manual reset button circuit breaker (25 or 50 amp)

F

Hose Inlet Kit (Page 259)

A hose inlet is required for installation. They are appropriately sized for the hose reels based on type of fluid, hose size and pressure.

REQUIRED FOR INSTALLATION

Note: All 1-1/2 in (38 mm) hose reels include a 2 in (51 mm) Victaulic-style groove on inlet. If you are using these reels, it is recommended to order an inlet kit from Graco.

- Yes (required for installation)
- No (will supply my own hose inlet kit)

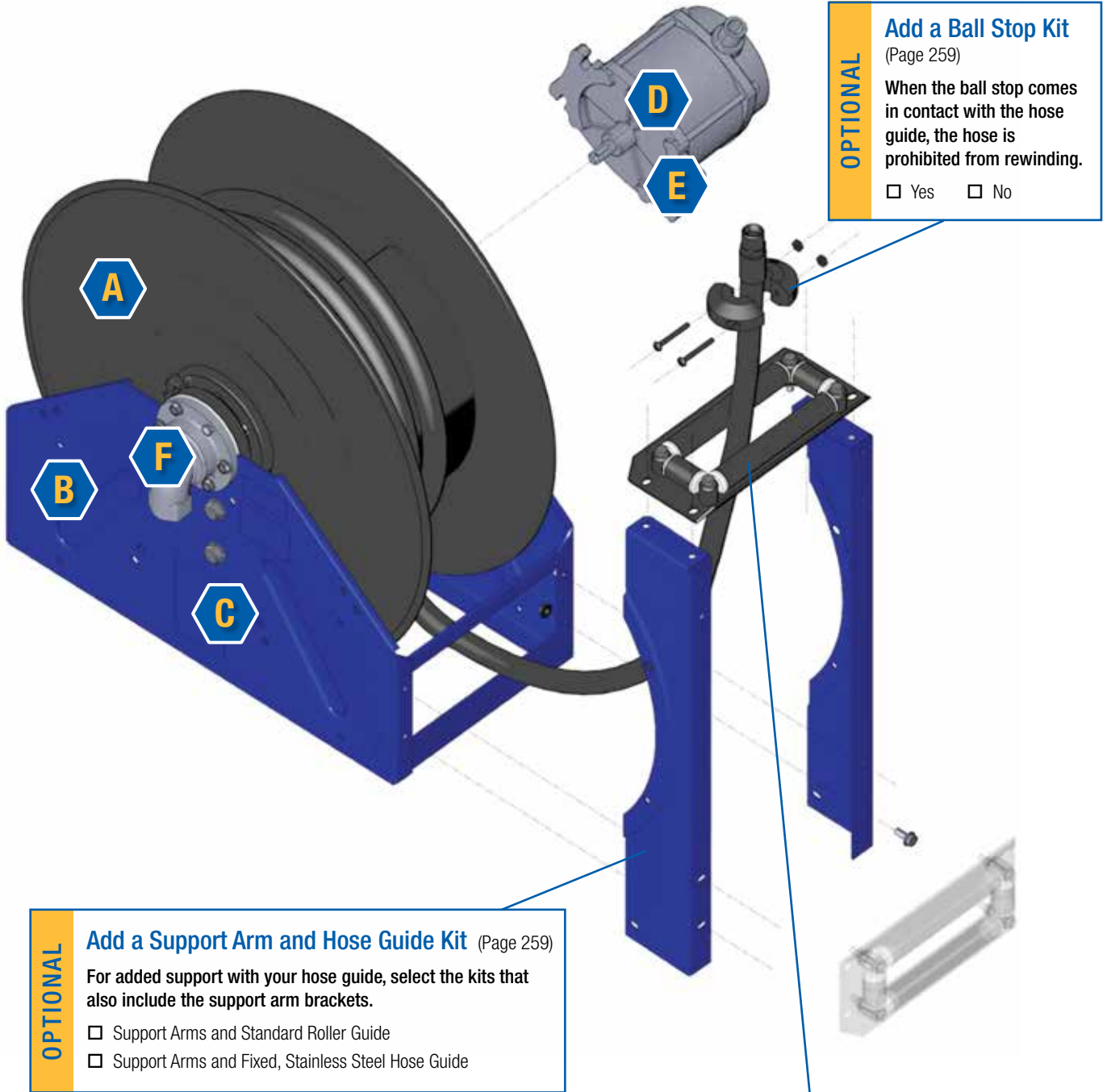

OPTIONAL

Add a Ball Stop Kit
(Page 259)

When the ball stop comes in contact with the hose guide, the hose is prohibited from rewinding.

Yes No

OPTIONAL

Add a Support Arm and Hose Guide Kit (Page 259)

For added support with your hose guide, select the kits that also include the support arm brackets.

Support Arms and Standard Roller Guide
 Support Arms and Fixed, Stainless Steel Hose Guide

OPTIONAL

Add a Hose Guide Kit (Page 259)

Select between a fixed, stainless steel hose guide or a general roller guide.

Hose guide mounts directly to the reel frame or in three different positions on the support arm.

Standard Roller Guide
 Fixed, Stainless Steel Hose Guide

XD Series Bare Hose Reels



60 / 70 / 80

Ordering Information

Reel with Motor – 1 in (25 mm) Inlet/Outlet

XD 60 Reels

| Reel Size | Fluid | Motor | Hose Capacity of Reel ft (m) | | | Maximum Pressure psi (bar) | Weight lb (kg) | Inlet/Outlet Size NPT(F) | Reel Part Number by Color | | | Hose Accessories (Must be ordered separately) | | | |
|------------------|----------------------------|----------------------------|------------------------------|----------|-------------|----------------------------|----------------|--------------------------------|---------------------------|--------|--------|---|--|--------|---|
| | | | Hose ID in (mm) | | | | | | Metallic Blue | Yellow | White | Hose Inlet Kit | Hose | | |
| | | | 1/2 (13) | 3/4 (19) | 1 (25) | | | | | | | | | | |
| XD 6010 | Air/ Water | Pneumatic | 100 (30) | 100 (30) | 50 (15) | 600 (41) | 123 (56) | 1 in/1 in (25 mm/ 25 mm) | 24R419 | 24R420 | 24R421 | 24R111 | 126359 – 1/2 in x 100 ft (13 mm x 30 m) | | |
| | | Hydraulic | 100 (30) | 100 (30) | 50 (15) | 600 (41) | 101 (45) | | 24R414 | 24R415 | 24R416 | | 126360 – 3/4 in x 75 ft (19 mm x 23 m) | | |
| | | 12 VDC Electric, 1/2 HP | 100 (30) | 100 (30) | 50 (15) | 600 (41) | 133 (60) | | 24R404 | 24R405 | 24R406 | | 126361 – 3/4 in x 100 ft (19 mm x 30 m) | | |
| | | 24 VDC Electric, 1/2 HP | 100 (30) | 100 (30) | 50 (15) | 600 (41) | 133 (60) | | 24R407 | 24R408 | 24R409 | | 126362 – 1 in x 50 ft (25 mm x 15 m) | | |
| | | 115 VAC Electric | 100 (30) | 100 (30) | 50 (15) | 600 (41) | 133 (60) | | 24R410 | 24R412 | 24R413 | | 126375 – 1/2 in x 100 ft (13 mm x 30 m) | | |
| | | Pneumatic | 100 (30) | 100 (30) | 50 (15) | 3,000 (207) | 125 (56) | | 24R434 | 24R435 | 24R436 | | 126376 – 3/4 in x 75 ft (19 mm x 23 m) | | |
| | | Hydraulic | 100 (30) | 100 (30) | 50 (15) | 3,000 (207) | 103 (47) | | 24R431 | 24R432 | 24R433 | | 126377 – 3/4 in x 100 ft (19 mm x 30 m) | | |
| | | 12 VDC Electric, 1/2 HP | 100 (30) | 100 (30) | 50 (15) | 3,000 (207) | 134 (61) | | 24R422 | 24R423 | 24R424 | | 126503 – 1 in x 50 ft (25 mm x 15 m) | | |
| | 24 VDC Electric, 1/2 HP | 100 (30) | 100 (30) | 50 (15) | 3,000 (207) | 134 (61) | 24R425 | 24R426 | 24R427 | | | | | | |
| | 115 VAC Electric | 100 (30) | 100 (30) | 50 (15) | 3,000 (207) | 134 (61) | 24R428 | 24R429 | 24R430 | | | | | | |
| | Diesel Fuel | Pneumatic | 100 (30) | 100 (30) | 50 (15) | 600 (41) | 123 (56) | 1 in/1 in (25 mm/ 25 mm) | 24R419 | 24R420 | 24R421 | 24R115 | 24R102 – 1 in x 50 ft (25 mm x 15 m) | | |
| | | Hydraulic | 100 (30) | 100 (30) | 50 (15) | 600 (41) | 101 (45) | | 24R414 | 24R415 | 24R416 | | | | |
| | | 12 VDC Electric, 1/2 HP | 100 (30) | 100 (30) | 50 (15) | 600 (41) | 133 (60) | | 24R404 | 24R405 | 24R406 | | | | |
| | | 24 VDC Electric, 1/2 HP | 100 (30) | 100 (30) | 50 (15) | 600 (41) | 133 (60) | | 24R407 | 24R408 | 24R409 | | | | |
| | | 115 VAC Electric | 100 (30) | 100 (30) | 50 (15) | 600 (41) | 133 (60) | | 24R410 | 24R412 | 24R413 | | | | |
| | | Pneumatic | – | – | 50 (15) | 600 (41) | 123 (56) | | 24R419 | 24R420 | 24R421 | | | 24R112 | 126379 – 1 in x 50 ft (25 mm x 15 m) |
| | | Hydraulic | – | – | 50 (15) | 600 (41) | 101 (45) | | 24R414 | 24R415 | 24R416 | | | | |
| | | 12 VDC Electric, 1/2 HP | – | – | 50 (15) | 600 (41) | 133 (60) | | 24R404 | 24R405 | 24R406 | | | | |
| | 24 VDC Electric, 1/2 HP | – | – | 50 (15) | 600 (41) | 133 (60) | 24R407 | 24R408 | 24R409 | | | | | | |
| | 115 VAC Electric | – | – | 50 (15) | 600 (41) | 133 (60) | 24R410 | 24R412 | 24R413 | | | | | | |
| | Grease | Pneumatic | – | – | 50 (15) | 3,000 (207) | 125 (75) | 1 in/1 in (25 mm/ 25 mm) | 24R434 | 24R435 | 24R436 | – | – | | |
| | | Hydraulic | – | – | 50 (15) | 3,000 (207) | 103 (47) | | 24R431 | 24R432 | 24R433 | | | | |
| | | 12 VDC Electric, 1/2 HP | – | – | 50 (15) | 3,000 (207) | 134 (61) | | 24R422 | 24R423 | 24R424 | | | | |
| | | 24 VDC Electric, 1/2 HP | – | – | 50 (15) | 3,000 (207) | 134 (61) | | 24R425 | 24R426 | 24R427 | | | | |
| 115 VAC Electric | | – | – | 50 (15) | 3,000 (207) | 134 (61) | 24R428 | | 24R429 | 24R430 | | | | | |

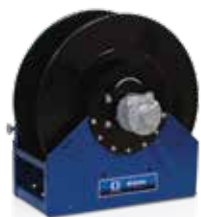

Hose and Cord Reels

Remember to Order!

| | | | | |
|---|--|---|---|--|
|  Ball Stop Kit See page 259 |  Hose Guide See page 259 |  Support Arm See page 259 |  Hose See page 260-261 |  Hose Inlet See page 259 |
|---|--|---|---|--|

Ordering Information

Reel with Motor – 1 in (25 mm) Inlet/Outlet

XD 70 / XD 80 Reels

| Reel Size | Fluid | Motor | Hose Capacity of Reel ft (m) | | Maximum Pressure psi (bar) | Weight lb (kg) | Inlet/Outlet Size NPT(F) | Reel Part Number by Color | | | Hose Accessories (Must be ordered separately) | |
|-----------|-------------|-------------------------|------------------------------|-------------|----------------------------|-------------------------|--------------------------|---------------------------|--------|--------|---|------|
| | | | Hose ID 1 in (25 mm) | | | | | Metallic Blue | Yellow | White | Hose Inlet Kit | Hose |
| XD 7010 | Air/Water | Pneumatic | 100 (30) | 600 (41) | 122 (55) | 1 in/1 in (25 mm/25 mm) | 24R449 | 24R450 | 24R451 | 24R111 | 126363 – 1 in x 75 ft (25 mm x 23 m) 126364 – 1 in x 100 ft (25 mm x 30 m) | |
| | | Hydraulic | 100 (30) | 600 (41) | 100 (45) | | 24R446 | 24R447 | 24R448 | | | |
| | | 12 VDC Electric, 1/2 HP | 100 (30) | 600 (41) | 132 (60) | | 24R437 | 24R438 | 24R439 | | | |
| | | 24 VDC Electric, 1/2 HP | 100 (30) | 600 (41) | 132 (60) | | 24R440 | 24R441 | 24R442 | | | |
| | | 115 VAC Electric | 100 (30) | 600 (41) | 132 (60) | | 24R443 | 24R444 | 24R445 | | | |
| | Oil | Pneumatic | 100 (30) | 3,000 (207) | 100 (56) | 1 in/1 in (25 mm/25 mm) | 24R464 | 24R465 | 24R466 | | 126504 – 1 in x 75 ft (25 mm x 23 m) 126505 – 1 in x 100 ft (25 mm x 30 m) | |
| | | Hydraulic | 100 (30) | 3,000 (207) | 102 (46) | | 24R461 | 24R462 | 24R463 | | | |
| | | 12 VDC Electric, 1/2 HP | 100 (30) | 3,000 (207) | 133 (60) | | 24R452 | 24R453 | 24R454 | | | |
| | | 24 VDC Electric, 1/2 HP | 100 (30) | 3,000 (207) | 133 (60) | | 24R455 | 24R456 | 24R457 | | | |
| | | 115 VAC Electric | 100 (30) | 3,000 (207) | 133 (60) | | 24R458 | 24R459 | 24R460 | | | |
| | Diesel Fuel | Pneumatic | 100 (30) | 600 (41) | 122 (55) | 1 in/1 in (25 mm/25 mm) | 24R449 | 24R450 | 24R451 | 24R115 | 24R103 – 1 in x 75 ft (25 mm x 23 m) 24R106 – 1 in x 100 ft (25 mm x 30 m) | |
| | | Hydraulic | 100 (30) | 600 (41) | 100 (45) | | 24R446 | 24R447 | 24R448 | | | |
| | | 12 VDC Electric, 1/2 HP | 100 (30) | 600 (41) | 132 (60) | | 24R437 | 24R438 | 24R439 | | | |
| | | 24 VDC Electric, 1/2 HP | 100 (30) | 600 (41) | 132 (60) | | 24R440 | 24R441 | 24R442 | | | |
| | | 115 VAC Electric | 100 (30) | 600 (41) | 132 (60) | | 24R443 | 24R444 | 24R445 | | | |
| XD 8010 | Air/Water | Pneumatic | 150 (46) | 600 (41) | 164 (74) | 1 in/1 in (25 mm/25 mm) | 24R531 | 24R532 | 24R533 | 24R111 | - | |
| | | Hydraulic | 150 (46) | 600 (41) | 142 (64) | | 24R528 | 24R529 | 24R530 | | | |
| | | 12 VDC Electric, 1/2 HP | 150 (46) | 600 (41) | 173 (78) | | 24R519 | 24R520 | 24R521 | | | |
| | | 24 VDC Electric, 1/2 HP | 150 (46) | 600 (41) | 173 (78) | | 24R522 | 24R523 | 24R524 | | | |
| | | 115 VAC Electric | 150 (46) | 600 (41) | 173 (78) | | 24R525 | 24R526 | 24R527 | | | |
| | Oil | Pneumatic | 150 (46) | 3,000 (207) | 165 (75) | 1 in/1 in (25 mm/25 mm) | 24R546 | 24R547 | 24R548 | | - | |
| | | Hydraulic | 150 (46) | 3,000 (207) | 143 (65) | | 24R543 | 24R544 | 24R545 | | | |
| | | 12 VDC Electric, 1/2 HP | 150 (46) | 3,000 (207) | 175 (79) | | 24R534 | 24R535 | 24R536 | | | |
| | | 24 VDC Electric, 1/2 HP | 150 (46) | 3,000 (207) | 175 (79) | | 24R537 | 24R538 | 24R539 | | | |
| | | 115 VAC Electric | 150 (46) | 3,000 (207) | 175 (79) | | 24R540 | 24R541 | 24R542 | | | |
| | Diesel Fuel | Pneumatic | 150 (46) | 600 (41) | 164 (74) | 1 in/1 in (25 mm/25 mm) | 24R531 | 24R532 | 24R533 | 24R115 | 24T252 – 1 in x 150 ft (25 mm x 46 m) | |
| | | Hydraulic | 150 (46) | 600 (41) | 142 (64) | | 24R528 | 24R529 | 24R530 | | | |
| | | 12 VDC Electric, 1/2 HP | 150 (46) | 600 (41) | 173 (78) | | 24R519 | 24R520 | 24R521 | | | |
| | | 24 VDC Electric, 1/2 HP | 150 (46) | 600 (41) | 173 (78) | | 24R522 | 24R523 | 24R524 | | | |
| | | 115 VAC Electric | 150 (46) | 600 (41) | 173 (78) | | 24R525 | 24R526 | 24R527 | | | |



Hose and Cord Reels

Remember to Order!

| | | | | |
|--|---|--|---|---|
|  <p>Ball Stop Kit See page 259</p> |  <p>Hose Guide See page 259</p> |  <p>Support Arm See page 259</p> |  <p>Hose See page 260-261</p> |  <p>Hose Inlet See page 259</p> |
|--|---|--|---|---|

XD Series Bare Hose Reels



60 / 70 / 80

Ordering Information

Reel with Motor – 1-1/2 in (38 mm) Inlet/Outlet

XD 70 / XD 80 Reels

| Reel Size | Fluid | Motor | Hose Capacity of Reel ft (m) | Maximum Pressure psi (bar) | Weight lb (kg) | Inlet/Outlet Size NPT(F) | Reel Part Number by Color | | | Hose Accessories (Must be ordered separately) | |
|-----------|-------------------------|-------------------------|------------------------------|----------------------------|----------------|-------------------------------------|---------------------------|--------|--------|---|--|
| | | | Hose ID 1-1/2 in (38 mm) | | | | Metallic Blue | Yellow | White | Hose Inlet Kit | Hose |
| XD 7015 | Diesel Fuel | Pneumatic | 65 (20) | 600 (41) | 100 (56) | 1-1/2 in / 1-1/2 in (38 mm / 38 mm) | 24R516 | 24R517 | 24R518 | 24R117 | 24R110 – 1-1/4 in x 50 ft (32 mm x 15 m) 24R114 – 1-1/2 in x 50 ft (38 mm x 15 m) |
| | | Hydraulic | 65 (20) | 600 (41) | 102 (46) | | 24R512 | 24R513 | 24R515 | | |
| | | 12 VDC Electric, 1/2 HP | 65 (20) | 600 (41) | 133 (60) | | 24R503 | 24R504 | 24R505 | | |
| | | 24 VDC Electric, 1/2 HP | 65 (20) | 600 (41) | 133 (60) | | 24R506 | 24R507 | 24R508 | | |
| | | 115 VAC Electric | 65 (20) | 600 (41) | 133 (60) | | 24R509 | 24R510 | 24R511 | | |
| | Waste Oil Evac. | Pneumatic | 50 (15) | 600 (41) | 100 (56) | | 24R516 | 24R517 | 24R518 | - | 126380 – 1-1/4 in x 35 ft (32 mm x 11 m) 126688 – 1-1/4 in x 50 ft (32 mm x 15 m) 127173 – 1-1/2 in x 50 ft (38 mm x 15 m) |
| | | Hydraulic | 50 (15) | 600 (41) | 102 (46) | | 24R512 | 24R513 | 24R515 | | |
| | | 12 VDC Electric, 1/2 HP | 50 (15) | 600 (41) | 133 (60) | | 24R503 | 24R504 | 24R505 | | |
| | | 24 VDC Electric, 1/2 HP | 50 (15) | 600 (41) | 133 (60) | | 24R506 | 24R507 | 24R508 | | |
| | | 115 VAC Electric | 50 (15) | 600 (41) | 133 (60) | | 24R509 | 24R510 | 24R511 | | |
| XD 8015 | Diesel Fuel | Pneumatic | 100 (50) | 600 (41) | 165 (75) | 24R561 | 24R562 | 24R563 | 24R117 | 24T253 – 1-1/2 in x 100 ft (38 mm x 30 m) | |
| | | Hydraulic | 100 (50) | 600 (41) | 143 (65) | 24R558 | 24R559 | 24R560 | | | |
| | | 12 VDC Electric, 1/2 HP | 100 (50) | 600 (41) | 175 (79) | 24R549 | 24R550 | 24R551 | | | |
| | 24 VDC Electric, 1/2 HP | 100 (50) | 600 (41) | 175 (79) | 24R552 | 24R553 | 24R554 | | | | |
| | 115 VAC Electric | 100 (50) | 600 (41) | 175 (79) | 24R555 | 24R556 | 24R557 | | | | |

Reel with Motor – 2 in (51 mm) Inlet/Outlet

XD 70 / XD 80 Reels

| Reel Size | Fluid | Motor | Hose Capacity of Reel ft (m) | Maximum Pressure psi (bar) | Weight lb (kg) | Inlet/Outlet Size NPT(F) | Reel Part Number by Color | | | Hose Accessories (Must be ordered separately) | |
|-------------------------|-------------|-------------------------|------------------------------|----------------------------|----------------|---------------------------|---------------------------|--------|--------|---|--------------------------------------|
| | | | Hose ID 2 in (51 mm) | | | | Metallic Blue | Yellow | White | Hose Inlet Kit | Hose |
| XD 7020 | Diesel Fuel | Pneumatic | 33 (10) | 600 (41) | 128 (58) | 2 in/2 in (51 mm / 51 mm) | 24T023 | 24T024 | 24T025 | 24R118 | 127167 – 2 in x 33 ft (51 mm x 10 m) |
| | | Hydraulic | 33 (10) | 600 (41) | 106 (48) | | 24T020 | 24T021 | 24T022 | | |
| | | 12 VDC Electric, 1/2 HP | 33 (10) | 600 (41) | 137 (62) | | 24T011 | 24T012 | 24T013 | | |
| | | 24 VDC Electric, 1/2 HP | 33 (10) | 600 (41) | 137 (62) | | 24T014 | 24T015 | 24T016 | | |
| | | 115 VAC Electric | 33 (10) | 600 (41) | 137 (62) | | 24T017 | 24T018 | 24T019 | | |
| | | XD 8020 | Pneumatic | 50 (15) | 600 (41) | | 169 (76) | 24R576 | 24R577 | | |
| Hydraulic | 50 (15) | | 600 (41) | 147 (67) | 24R573 | | 24R574 | 24R575 | | | |
| 12 VDC Electric, 1/2 HP | 50 (15) | | 600 (41) | 179 (81) | 24R564 | | 24R565 | 24R566 | | | |
| 24 VDC Electric, 1/2 HP | 50 (15) | | 600 (41) | 179 (81) | 24R567 | | 24R568 | 24R569 | | | |
| 115 VAC Electric | 50 (15) | | 600 (41) | 179 (81) | 24R570 | | 24R571 | 24R572 | | | |

Remember to Order!

| | | | | |
|---|--|---|---|--|
|  Ball Stop Kit See page 259 |  Hose Guide See page 259 |  Support Arm See page 259 |  Hose See page 260-261 |  Hose Inlet See page 259 |
|---|--|---|---|--|



Ordering Information

Reel Frames Only

XD 60 / XD 70 / XD 80 Reels

Motor is not included and must be purchased separately.

| Reel Size | Fluid | Hose Capacity of Reel ft (m) | | | | | Maximum Pressure psi (bar) | Weight lb (kg) | Inlet/Outlet Size NPT(F) | Reel Part Number by Color | | | |
|-----------|-----------------------|------------------------------|----------|----------|------------|----------|----------------------------|-------------------------|--------------------------|---------------------------------|--------|--------|--------|
| | | Hose ID in (mm) | | | | | | | | Metallic Blue | Yellow | White | |
| | | 1/2 (13) | 3/4 (19) | 1 (25) | 1-1/2 (38) | 2 (51) | | | | | | | |
| XD 6010 | Air/Water/Diesel Fuel | 100 (30) | 100 (30) | 50 (15) | - | - | 600 (41) | 87 (39) | 1 in/1 in (25 mm/25 mm) | 24T104 | 24T105 | 24T106 | |
| | Oil | 100 (30) | 100 (30) | 50 (15) | - | - | 3,000 (207) | 88 (40) | | 24T107 | 24T108 | 24T109 | |
| | Waste Oil Evac. | - | - | 50 (15) | - | - | 600 (41) | 87 (39) | | 24T104 | 24T105 | 24T106 | |
| | Grease | - | - | 50 (15) | - | - | 3,000 (207) | 88 (40) | | 24T107 | 24T108 | 24T109 | |
| XD 7010 | Air/Water/Diesel Fuel | - | - | 100 (30) | - | - | 600 (41) | 86 (39) | | 24T110 | 24T111 | 24T112 | |
| | Oil | - | - | 100 (30) | - | - | 3,000 (207) | 87 (39) | | 24T113 | 24T114 | 24T115 | |
| XD 8010 | Air/Water/Diesel Fuel | - | - | 150 (46) | - | - | 600 (41) | 127 (58) | | 24T122 | 24T123 | 24T124 | |
| | Oil | - | - | 150 (46) | - | - | 3,000 (207) | 129 (58) | | 24T125 | 24T126 | 24T127 | |
| XD 7015 | Diesel Fuel | Waste Oil Evac. | - | - | 50 (15) | - | 600 (41) | 87 (39) | | 1-1/2 in/1-1/2 in (38 mm/38 mm) | 24T116 | 24T117 | 24T118 |
| | | - | - | - | 65 (20) | - | 600 (41) | 87 (39) | | | 24T116 | 24T117 | 24T118 |
| XD 8015 | - | - | - | 100 (30) | - | 600 (41) | 129 (58) | 24T128 | | | 24T129 | 24T130 | |
| XD 7020 | - | - | - | - | 33 (10) | 600 (41) | 91 (41) | 2 in/2 in (51 mm/51 mm) | | | 24T119 | 24T120 | 24T121 |
| XD 8020 | - | - | - | - | 50 (15) | 600 (41) | 133 (60) | | 24T131 | | 24T132 | 24T133 | |

Motor Assemblies – Pair with Frame-Only Models

| Image | Part Number | Description |
|-------|-------------|--|
| | 24T892 | Pneumatic motor assembly, reversible type. For installing motor to bare XD reel. |
| | 24T891 | Hydraulic motor assembly, reversible type. For installing motor to bare XD reel. |
| | 24T886 | 12 VDC, 1/2 HP motor assembly, reversible type. For installing motor to bare XD frame. |
| | 24T910 | 12 VDC, 2/3 HP motor assembly, reversible type. For installing motor to bare XD frame. |
| | 24T888 | 24 VDC, 1/2 HP motor assembly, reversible type. For installing motor to bare XD frame. |
| | 24T911 | 24 VDC, 2/3 HP motor assembly, reversible type. For installing motor to bare XD frame. |
| | 24T889 | 115 VAC, 0.40 HP motor assembly, reversible type. For installing motor to bare XD frame. |

Remember to Order!









| | | | | |
|--------------------------------------|-----------------------------------|------------------------------------|---------------------------------|-----------------------------------|
| | | | | |
| Ball Stop Kit See page 259 | Hose Guide See page 259 | Support Arm See page 259 | Hose See page 260-261 | Hose Inlet See page 259 |

Hose and Cord Reels



Ordering Information

Motor Controls (Required)

| | Part Number | Description |
|---|-------------|--|
|  | 127271 | Pneumatic valve to control XD 60/70/80 pneumatic powered hose reels. 2-position, 3-way valve. |
|  | 24T875 | Hydraulic control module for electric over hydraulic control of XD 60/70/80 hydraulic powered hose reels, 12 VDC. 3-position, 4-way valve. |
| | 24T876 | Hydraulic control module for electric over hydraulic control of XD 60/70/80 hydraulic powered hose reels, 24 VDC. 3-position, 4-way valve. |
|  | 127224 | Hydraulic control module for electric over hydraulic control of XD 60/70/80 hydraulic powered hose reels, 12V, includes switch. 3-position, 4-way valve. |
| | 127225 | Hydraulic control module for electric over hydraulic control of XD 60/70/80 hydraulic powered hose reels, 24V, includes switch. 3-position, 4-way valve. |
|  | 127214 | Momentary push-button on/off switch with red rubber cap. Use for 12 or 24 VDC. |
|  | 127217 | Hazardous-location push-button on/off switch. Use for 12 and 24 VDC. |
| | 127223 | Hazardous-location push-button on/off switch. Use for 115 and 220 VAC. |
|  | 127218 | Hazardous-location junction box |
|  | 127219 | 12 VDC intermittent-duty solenoid recommended for activating rewind on 12 VDC motor |
| | 127220 | 24 VDC intermittent-duty solenoid recommended for activating rewind on 24 VDC motor |
|  | 127221 | Manual-reset push-button circuit breaker, 50 amp rating |
| | 127222 | Manual-reset push-button circuit breaker, 25 amp rating |





XD Series Bare Hose Reel Accessories

Ordering Information



Ball Stop Kits

|  | Part Number | Description |
|---|-------------|---|
| | 237873 | Ball stop kit used for 3/4 in (19 mm) hose |
| | 237874 | Ball stop kit used for 1 in (25 mm) hose |
| | 24R060 | Ball stop kit used for 1.25 in (32 mm) hose |
| | 24R061 | Ball stop kit used for 1.5 in (38 mm) hose |

Hose Guide

|  | Part Number | Description |
|---|-------------|---|
| | 24T327 | Stainless steel hose guide for XD 60 |
| | 24T328 | Stainless steel hose guide for XD 70 |
|  | 24T329 | Stainless steel hose guide for XD 80 |
| | 24R072 | Roller guide kit with bracket for XD 40 and XD 60 |
| | 24T330 | Roller guide kit with bracket for XD 70 |
| | 24T331 | Roller guide kit with bracket for XD 80 |

Support Arm Kit with Hose Guide

|  | Part Number | Description |
|---|-------------|--|
| | 24T332 | Arm kit with stainless steel hose guide for XD 60 (24T327) |
| | 24T333 | Arm kit with stainless steel hose guide for XD 70 (24T328) |
|  | 24T334 | Arm kit with stainless steel hose guide for XD 80 (24T329) |
| | 24T335 | Arm kit with roller guide for XD 60 (24R072) |
| | 24T336 | Arm kit with roller guide for XD 70 (24T330) |
| | 24T337 | Arm kit with roller guide for XD 80 (24T331) |

Hose Inlet Kits

|  | Part Number | Description |
|---|-------------|--|
| | 24R111 | 1 in (25 mm) hose inlet kit for air/water and oil 1,275 psi (88 bar), 1 in NPT hose inlet ID, 28 in (710 mm) long |
| | 24R112 | 1 in (25 mm) hose inlet kit for waste oil evacuation 250 psi (17 bar), 1 in NPT hose inlet ID, 28 in (710 mm) long |
| | 24R115 | 1 in (25 mm) hose inlet kit for diesel fuel 250 psi (17 bar), 1 in NPT hose inlet ID, 28 in (710 mm) long |
| | 24R117 | 1-1/2 in (38 mm) hose inlet kit for diesel fuel 150 psi (10 bar), 1-1/2 in NPT hose inlet ID, 28 in (710 mm) long |
| | 24R118 | 2 in (51 mm) hose inlet kit for diesel fuel 150 psi (10 bar), 2 in NPT hose inlet ID, 28 in (710 mm) long |
| | 24T858 | 1-1/2 in (38 mm) hose inlet kit for waste oil evacuation 150 psi (10 bar), 1-1/2 in NPT hose inlet ID, 28 in (710 mm) long |

Self-Adhesive Identification Label Set

|  | Part Number | Description |
|---|-------------|---|
| | 180698 | Set includes: 1 in x 5 in (25.4 mm x 127 mm) hose reels labels for Antifreeze, Water, SAE 5-40, SAE 10-40, SAE 20W, Hydraulic, Gear, SAE 10W, SAE 10-30, SAE 30W, Dexron, Air, Chassis, ATF |



Ordering Information

Hose Identification Wraps

Vinyl hose wrap for easy identification of meter fluid

| | Part Number | Description |
|---|-------------|-------------|
|  | 17S659 | Red |
|  | 17S660 | Blue |
|  | 17S661 | Green |
|  | 17S662 | Yellow |
|  | 17S663 | White |

Air/Water/Antifreeze Hoses

| | Part Number | Description | Compatible Reel Series |
|---|-------------|---|------------------------|
|  | 253848 | 3/8 in x 35 ft (10 mm x 11 m) hose for air/water, 300 psi (20.6 bar) | SDX 10, XDX 10 |
| | 253849 | 3/8 in x 50 ft (10 mm x 15 m) hose for air/water, 300 psi (20.6 bar) | SDX 10, XDX 10 |
| | 253850 | 3/8 in x 65 ft (10 mm x 20 m) hose for air/water, 300 psi (20.6 bar) | SDX 20, XDX 20 |
| | 253852 | 1/2 in x 35 ft (13 mm x 11 m) hose for air/water, 300 psi (20.6 bar) | SDX 10, XDX 10 |
| | 253853 | 1/2 in x 50 ft (13 mm x 15 m) hose for air/water, 300 psi (20.6 bar) | SDX 20, XDX 20 |
| | 16A684 | 1/2 in x 75 ft (13 mm x 23 m) hose for air/water, 300 psi (20.6 bar) | XD 30 |
| | 126359 | 1/2 in x 100 ft (13 mm x 30 m) hose for air/water, 300 psi (20.6 bar) | XD 40, XD 60 |
| | 16A707 | 3/4 in x 50 ft (19 mm x 15 m) hose for air/water, 300 psi (20.6 bar) | XD 30 |
| | 126360 | 3/4 in x 75 ft (19 mm x 23 m) hose for air/water, 300 psi (20.6 bar) | XD 40 |
| | 126361 | 3/4 in x 100 ft (19 mm x 30 m) hose for air/water, 300 psi (20.6 bar) | XD 40, XD 60 |
| | 126362 | 1 in x 50 ft (25 mm x 15 m) hose for air/water, 300 psi (20.6 bar) | XD 40, XD 60 |
| | 126363 | 1 in x 75 ft (25 mm x 23 m) hose for air/water, 300 psi (20.6 bar) | XD 50 |
| | 126364 | 1 in x 100 ft (25 mm x 30 m) hose for air/water, 300 psi (20.6 bar) | XD 50, XD 70 |

Oil Hoses

| | Part Number | Description | Compatible Reel Series |
|---|-------------|--|------------------------|
|  | 26C121 | 1/2 in x 35 ft (13 mm x 11 m) hose for oil, 2,000 psi (138 bar) | SDX 10, XDX 10 |
| | 26C122 | 1/2 in x 50 ft (13 mm x 15 m) hose for oil, 2,000 psi (138 bar) | SDX 20, XDX 20 |
| | 26C123 | 1/2 in x 75 ft (13 mm x 23 m) hose for oil, 2,000 psi (138 bar) | XD 30 |
| | 26C124 | 1/2 in x 100 ft (13 mm x 30 m) hose for oil, 2,000 psi (138 bar) | XD 40, XD 60 |
| | 126376 | 3/4 in x 75 ft (19 mm x 23 m) hose for oil, 1,500 psi (103 bar) | XD 40, XD 60 |
| | 126377 | 3/4 in x 100 ft (19 mm x 30 m) hose for oil, 1,500 psi (103 bar) | XD 40, XD 60 |
| | 126503 | 1 in x 50 ft (25 mm x 15 m) hose for oil, 1,275 psi (88 bar) | XD 40, XD 60 |
| | 126504 | 1 in x 75 ft (25 mm x 23 m) hose for oil, 1,275 psi (88 bar) | XD 50 |
| | 126505 | 1 in x 100 ft (25 mm x 30 m) hose for oil, 1,275 psi (88 bar) | XD 70, XD 80 |

Ordering Information

Grease Hoses

|  | Part Number | Description | Compatible Reel Series |
|---|-------------|--|------------------------|
| | 109158 | 1/4 in x 50 ft (6 mm x 15m) hose for grease, 5,000 psi (345 bar) | SDX 10, XDX 10 |
| | 124470 | 3/8 in x 35 ft (10 mm x 11 m) hose for grease, 4,800 psi (331 bar) | SDX 10, XDX 10 |
| | 124461 | 3/8 in x 50 ft (10 mm x 15 m) hose for grease, 4,800 psi (331 bar) | SDX 20, XDX 20 |
| | 126076 | 3/8 in x 75 ft (10 mm x 23m) hose for grease, 5,000 psi (345 bar) | XD 30 |
| | 16A674 | 1/2 in x 50 ft (13 mm x 15 m) hose for grease, 5,000 psi (345 bar) | XD 30 |

Waste Oil Evacuation Hoses

|  | Part Number | Description | Compatible Reel Series |
|---|-------------|--|------------------------|
| | 16A686 | 1 in x 30 ft (25 mm x 9 m) hose for waste oil or fuel, 125 psi (9 bar) | XD 30 |
| | 126379 | 1 in x 50 ft (25 mm x 15 m) hose for waste oil, 250 psi (17 bar) | XD 40, XD 60 |
| | 126380 | 1 1/4 in x 35 ft (32 mm x 10.5 m) hose for waste oil, 200 psi (13.8 bar) | XD 50 |
| | 126688 | 1 1/4 in x 50 ft (32 mm x 15 m) hose for waste oil, 200 psi (13.8 bar) | XD 50 |
| | 127173 | 1 1/2 in x 50 ft (38 mm x 15 m) hose for waste oil, 200 psi (13.8 bar) | XD 50 |

Diesel Fuel Hoses

|  | Part Number | Description | Compatible Reel Series |
|---|-------------|--|------------------------|
| | 16A686 | 1 in x 30 ft (25 mm x 9 m) hose for waste oil or fuel, 125 psi (9 bar) | XD 30 |
| | 24R102 | 1 in x 50 ft (25 mm x 15 m) hose for diesel fuel, 250 psi (17 bar) | XD 40, XD 60 |
| | 24R103 | 1 in x 75 ft (25 mm x 23 m) hose for diesel fuel, 250 psi (17 bar) | XD 50 |
| | 24R106 | 1 in x 100 ft (25 mm x 30 m) hose for diesel fuel, 250 psi (17 bar) | XD 50, XD 70 |
| | 24T252 | 1 in x 150 ft (25 mm x 46 m) hose for diesel fuel, 250 psi (17 bar) | XD 80 |
| | 24R108 | 1 1/4 in x 35 ft (32 mm x 10.5 m) hose for diesel fuel, 250 psi (17 bar) | XD 50 |
| | 24R110 | 1 1/4 in x 50 ft (32 mm x 15 m) hose for diesel fuel, 250 psi (17 bar) | XD 50 |
| | 24R114 | 1 1/2 in x 50 ft (38 mm x 15 m) hose for diesel fuel, 150 psi (11 bar) | XD 50 |
| | 24T253 | 1 1/2 in x 100 ft (38 mm x 30 m) hose for diesel fuel, 150 psi (11 bar) | XD 80 |
| | 127167 | 2 in x 33 ft (51 mm x 10 m) hose for diesel fuel, 150 psi (11 bar) | XD 80 |
| | 24T254 | 2 in x 50 ft (51 mm x 15 m) hose for diesel fuel, 150 psi (11 bar) | XD 80 |

Diesel Exhaust Fluid (DEF) Hoses

|  | Part Number | Description | Compatible Reel Series |
|---|-------------|--|------------------------|
| | 125242 | 3/4 in x 50 ft (19 mm x 15 m) hose for DEF fluid, 50 psi (3 bar) | XD 30 |

Pressure Wash Hoses

|  | Part Number | Description | Compatible Reel Series |
|---|-------------|---|------------------------|
| | 16A688 | 3/8 in x 75 ft (10 mm x 23m) hose for pressure wash, 4,000 psi (276 bar) | XD 30 |
| | 126075 | 1/2 in x 50 ft (13 mm x 15 m) hose for pressure wash, 4,500 psi (310 bar) | XD 30 |