

**Vision is
our mission[®]**



**HEAVY EQUIPMENT
VISION SOLUTIONS**

See more
Work more

3

Why Orlaco

6

Vision
solutions

16

Products

39

Certification

Excavator	6	Vibratory Soil Compactor	14
Material Handler	8	Compactor	14
Wheel loader	9	Skid steer loader	15
Crusher	9	Backhoe loader	15
Articulated dump truck	10		
Off-highway truck	11		
Telehandler	12		
Bulldozer	12		
Scraper	13		
Motor Grader	13		



Select
your
machine



Why Orlaco?

Welcome to the Orlaco product catalogue. We are personally committed to bringing you the best camera and monitor solutions possible. To help create safer and more secure workplaces around the world. Our professional team has spent over twenty-five years designing and manufacturing a variety of certified, reliable and complete camera display solutions that effectively eliminate the blind spots around vehicles, machinery and vessels. We are confident that the options offered in this catalogue will not only help you to improve the safety, security and efficiency of your fleet, but also to enhance the ergonomics and comfort for your operators. That is what Orlaco stands for. We invite you to share your ideas and experiences with us.

That's
why!

Let us
improve
your every
day job



Improved Safety and Efficiency

Shovels, excavators and dump trucks are examples of complex machines that require clear vision which allows the operation to progress smoothly and safely. Machines are increasingly becoming further advanced with elevated demands on efficiency and output. Still, it is people that are required to handle this equipment correctly. Operators have minimal vision around the vehicle. It is essential to solve large blind spots in a professional matter. This is where Orlaco's camera monitor solutions will help to improve operational efficiency and safety.



Why Orlaco



Enhanced Ergonomics and Comfort

An operator is required to follow what is occurring around his machine. Frequently he must maneuver into a contorted position. Machines are reversing repeatedly. The operator is obliged to turn his body to overview the operation, possibly leading to short or even long term ergonomic injuries. By viewing the Orlaco monitor located on the dashboard, the driver can maintain correct posture and work more comfortably. The driver feels safe, secure and in control of the machines environment, reducing stress and providing comfort.

Certified Quality

At Orlaco, quality is never taken lightly. We keep a clear and persistent focus on customer satisfaction. A focus that is maintained throughout the manufacturing process of our quality products, which are custom designed in various formats. We are able to uphold our level of quality by providing detailed servicing. To top it all off, we have secured the highest achievable automotive certification: TS16949. At Orlaco, we invest in continuous improvement in order to secure a long term, satisfied customer base. We believe that compatibility in products, systems, and operations is the key element to creating reliable partnerships. All our products are controlled and clearly documented to give our customers a zero-defect product with operation that works right, every time.

Earth moving sight solutions

Rearview / HD



PAGE 16

Not only safe reversing, but also good vision when turning the machine. Available in analog and digital version. The analog system can also be used in combination with Toolview (page 18) or an analog Sideview. (page 17)



Camera setting: Horizontal line mark.
This option shows a reference line on the monitor.

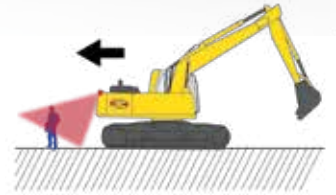

CornerEye



PAGE 22

CornerEye offers a complete and detailed view of 270° of the area around the rear of an excavator. The system delivers HD digital image quality in real time.

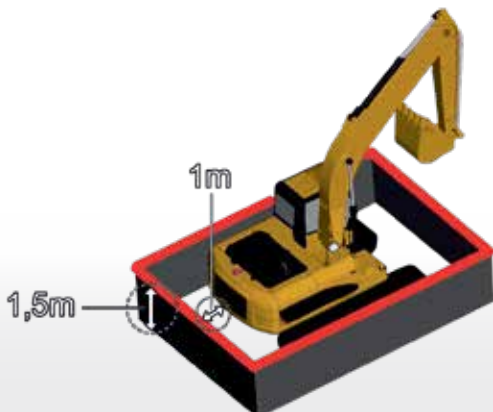

i INFORMATION

ISO 5006: 2006 Earth-moving Machinery Directive.
The red line must be clearly visible to the operator.



Toolview



PAGE 18

Clear view on a certain process when direct vision is not possible. This can also be used in combination with an analog Rearview. (page 18)



Sideview / HD

PAGE 16



If you are continually turning, you cannot always see what is happening next to the machine. A Sidecam is then the solution.

Available in analog and digital version.

The analog system can also be used in combination with an analog Rearview. (page 17)



8 Material Handler



Toolview



PAGE 18

Clear view on a certain process when direct vision is not possible. This can also be used in combination with an analog Rearview. (page 18)

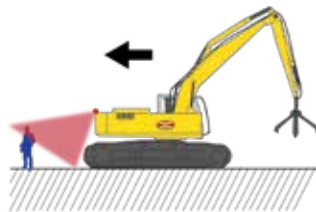
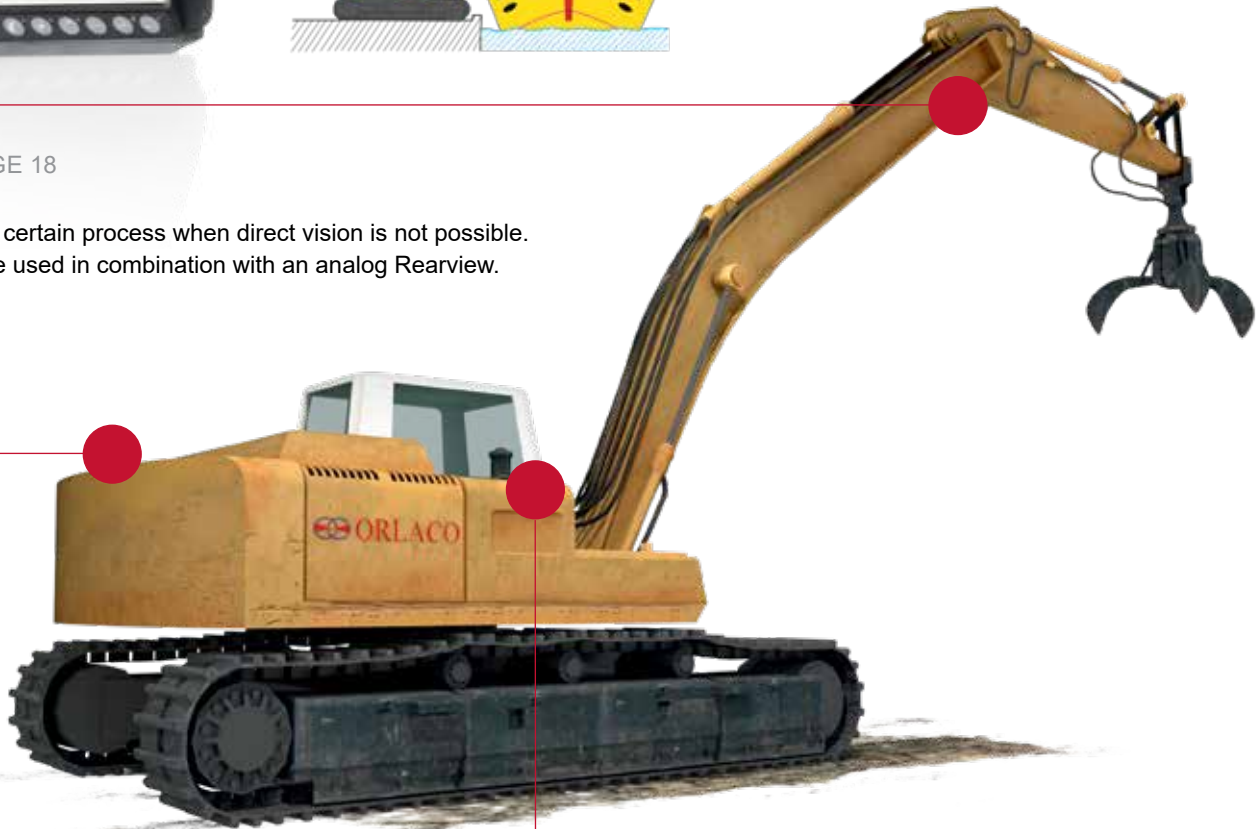

Rearview / HD



PAGE 16

Not only safe reversing, but also good vision when turning the machine. Available in analog and digital version. The analog system can also be used in combination with Toolview (page 18) or an analog Sideview. (page 17)

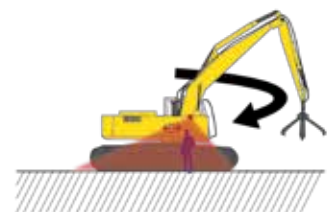

Sideview / HD



PAGE 16

If you are continually turning, you cannot always see what is happening next to the machine. A Sidecam is then the solution. Available in analog and digital version. The analog system can also be used in combination with an analog Rearview. (page 17)



Toolview



PAGE 18

Toolview provides good visibility to look over a load or the bucket.



RadarEye setting: Transparent visualization of the radar-zones on the display. (standard preset setting)

Rearview / HD



PAGE 16

Not only safe reversing, but also good vision when turning the machine. Available in analog and digital version.

Recommendation for analog systems:

Add RadarEye to increase safety & efficiency. (see page 32-33)

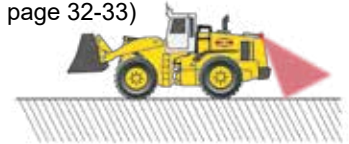

Toolview



PAGE 18

Clear view on a certain process when direct vision is not possible. For additional ease of use and safety, we also supply a video transmitter-receiver system. This allows the operator of, for instance, an excavator, to see what is happening at a distance and to always be aware of the status. To achieve this, the Toolview Set must be extended with a Spectrum Scanner. (see page 34)

Crusher

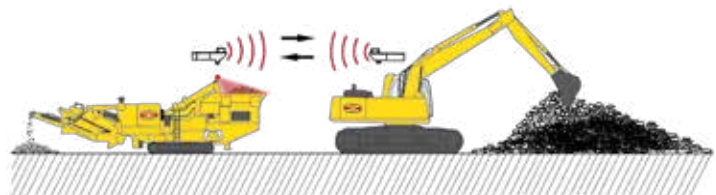

10 Articulated dump truck



Camera setting: Graticule.
This option shows a graticule for a Rearview camera on the monitor.

Rearview / HD



PAGE 16

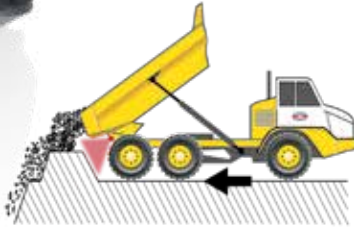

Not only safe reversing, but also good vision when turning the machine. Available in analog and digital version. The analog system can also be used in combination with an analog Sideview. (page 17)

Recommendation for analog systems: Add RadarEye to increase safety & efficiency. (see page 32-33)



Sideview / HD



PAGE 16

If you are continually turning, you cannot always see what is happening next to the machine. A Sidecam is then the solution. Available in analog and digital version. The analog system can also be used in combination with an analog Rearview. (page 17)



CornerEye

PAGE 22



CornerEye offers a complete and detailed view of 270° of the area around the cabin. The system delivers HD digital image quality in real time.





Roundview

PAGE 20



The Roundview Set guarantees good all round vision. The set consists of a Rearcam, Frontcam and two Sidecams.

Recommendation for analog systems:

Add RadarEye to increase safety & efficiency. (see page 32-33)



Multiview Box setting: Quad image (Monitor 12")



Surroundview



PAGE 21

Surround view offers 360 degrees visibility surrounding a vehicle. It gives the driver maximum visibility on all sides of the truck via one central monitor. This is due to the camera images overlapping. Therefore the driver is able to see every person and object around his vehicle.

Contact Orlaco for more information regarding Surround view.



12 Telehandler



Toolview



PAGE 18

Clear view on a certain process when direct vision is not possible. This can also be used in combination with an analog Rearview. (page 18)

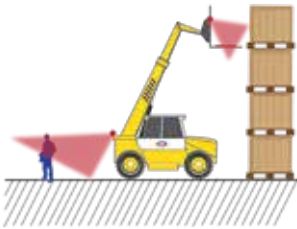

Bulldozer

Rearview / HD



PAGE 16

Not only safe reversing, but also good vision when turning the machine. Available in analog and digital version. The analog system can also be used in combination with Toolview. (page 18)





Rearview / HD



PAGE 16

Not only safe reversing, but also good vision when turning the machine. Available in analog and digital version. The analog system can also be used in combination with Toolview. (page 18)

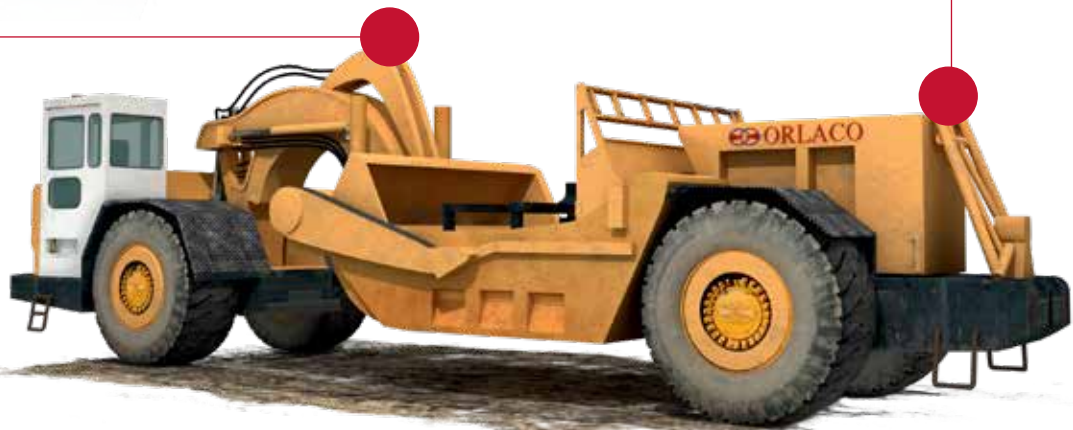

Motor grader

Toolview



PAGE 18

Clear view on a certain process when direct vision is not possible. It can also be used in combination with an analog Rearview. (page 18)



14 Vibratory soil compactor



Rearview / HD



PAGE 16

Not only safe reversing, but also good vision when turning the machine. Available in analog and digital version.

Recommendation for analog systems:

Add RadarEye to increase safety & efficiency. (see page 32-33)

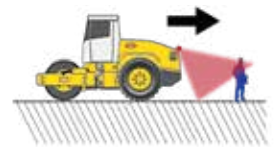

Compactor

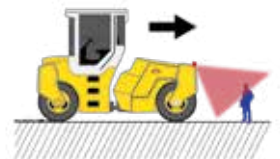



Rearview / HD



PAGE 16

Not only safe reversing, but also good vision when turning the machine. Available in analog and digital version.



Backhoe loader



Set **Rearview / Sideview**

1. Camera FAMOS 118°

0171110 - page 23

2. Monitor 7" RLED, including adjustable bracket 5.2 inch

0208672 - page 28

Cables

To be ordered separately, see page 26-27.

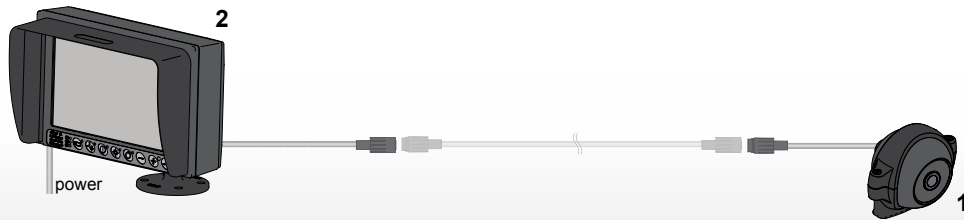

Set **HD Rearview / Sideview**

1. Camera HMOS 120° incl. bracket

0185010 - page 25

2. Monitor HLED 10" MR1

0224000 - page 28

3. Digicoax cable

Make your choice - page 27

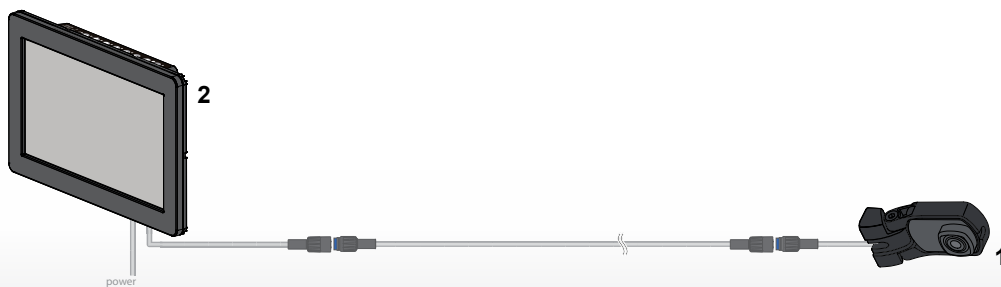

Set Rearview

- 1. Camera FAMOS 118°
0171110 - page 23
- 2. Monitor 7" RLED, including standard bracket
0208681 - page 28

Cables
To be ordered separately, see page 26-27.

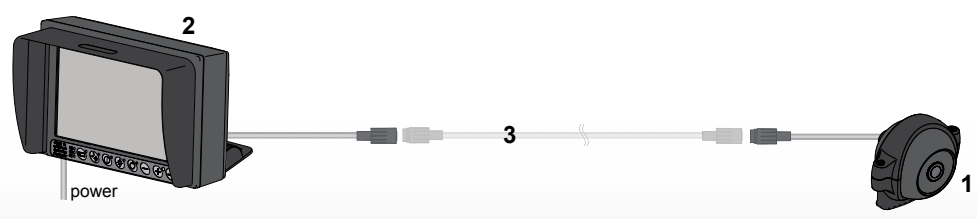

Set Rear-Sideview

- 1. Camera FAMOS 118° (2x)
0171110 - page 23
- 2. Monitor 7" RLED 4Cam, including adjustable bracket 5.2 inch
0208612 - page 28

Cables
To be ordered separately, see page 26-27.

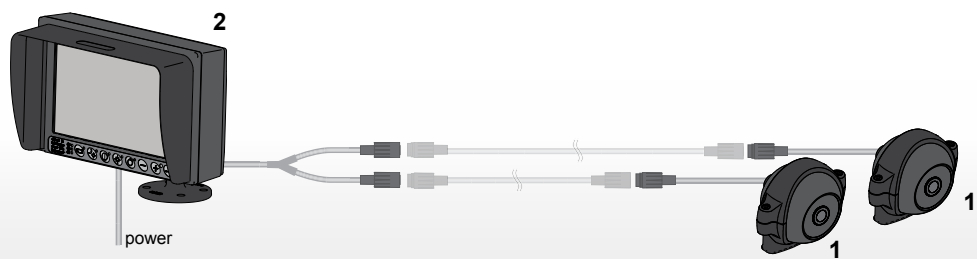

Set **Toolview**

1. Camera FAMOS 80°

0171130 - page 23

2. Monitor 7" RLED, including adjustable bracket 5.2 inch

0208672 - page 28

Cables

To be ordered separately, see page 26-27.

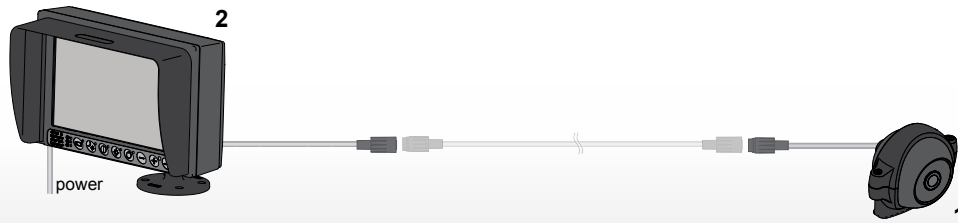

Set **Rear-Toolview**

1. Camera FAMOS 118° (Rear)

0171110 - page 23

2. Camera FAMOS 80° (Tool)

0171130 - page 23

3. Monitor 7" RLED 4Cam, including adjustable bracket 5.2 inch

0208612 - page 28

Cables

To be ordered separately, see page 26-27.

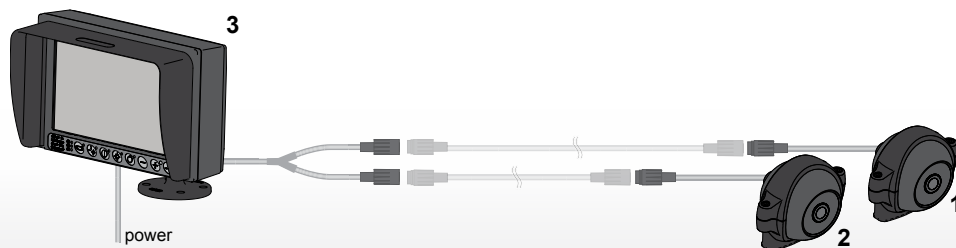

SRD Monitor (with 4p and 7p connectors)

You can easily expand your Orlaco SRD Monitor system with our active detection option (see RadarEye beneath).

1. Camera FAMOS 118° (4x)

0171110 - page 23

2. Monitor 7" RLED 4Cam CAN SRD, incl. adjustable bracket 5.2 inch

0209110 - page 28

3. Switcher UNI

0404040 - page 29

Cables

To be ordered separately, see page 26-27.

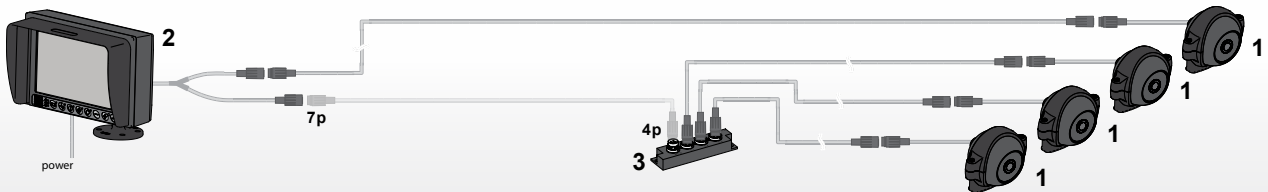

RadarEye expansion set for SRD Monitor (see above)

Expand your SRD monitor set with RadarEye by replacing the adapter cable for the RadarEye expansion set. Other cables to be ordered separately.

1. Set SRD Center Rear / Corner Rear

0403100 / 0403120 - page 32

2. Interface Box SRD

0504820 - page 33

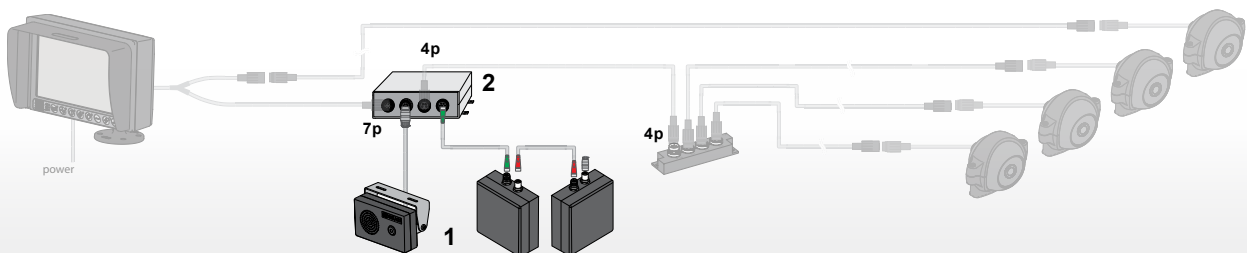
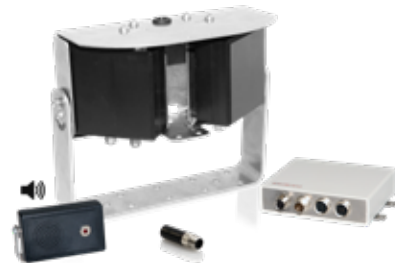

Set RadarEye

1. Camera FAMOS 118°

0171110 - page 23

2. Monitor 7" RLED SRD, including adjustable bracket 5.2 inch

0208871 - page 28

3. Set SRD Center Rear

0403100 - page 32

4. Interface Box SRD

0504820 - page 33

Cables

To be ordered separately, see page 26-27.

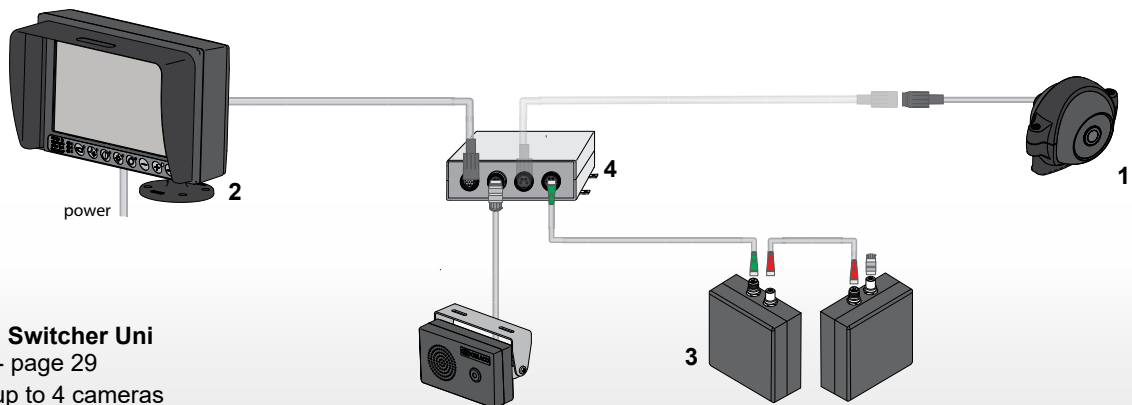

Optional: Switcher Uni

0404040 - page 29

Connect up to 4 cameras

Optional: Monitor 12" RLED SRD

0411300 - page 28

Set Surround view

1. Camera FAMOS 118° (4x)

0171110 - page 23

2. Monitor 7" RLED 4Cam, including adjustable bracket 5.2 inch

0208612 - page 28

3. Switcher UNI

0404040 - page 29

Cables

To be ordered separately, see page 26-27.

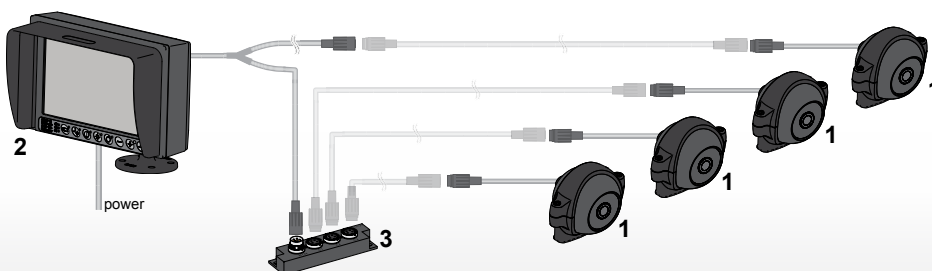

Set Surround view

- 1. Camera FAMOS 129° (4x)**
0171100 - page 23
- 2. Monitor 7" RLED Serial**
0208632 - page 28
- 3. Multiview box II**
0405100 - page 30
- 4. Multicable 16m**
0301920 - page 26

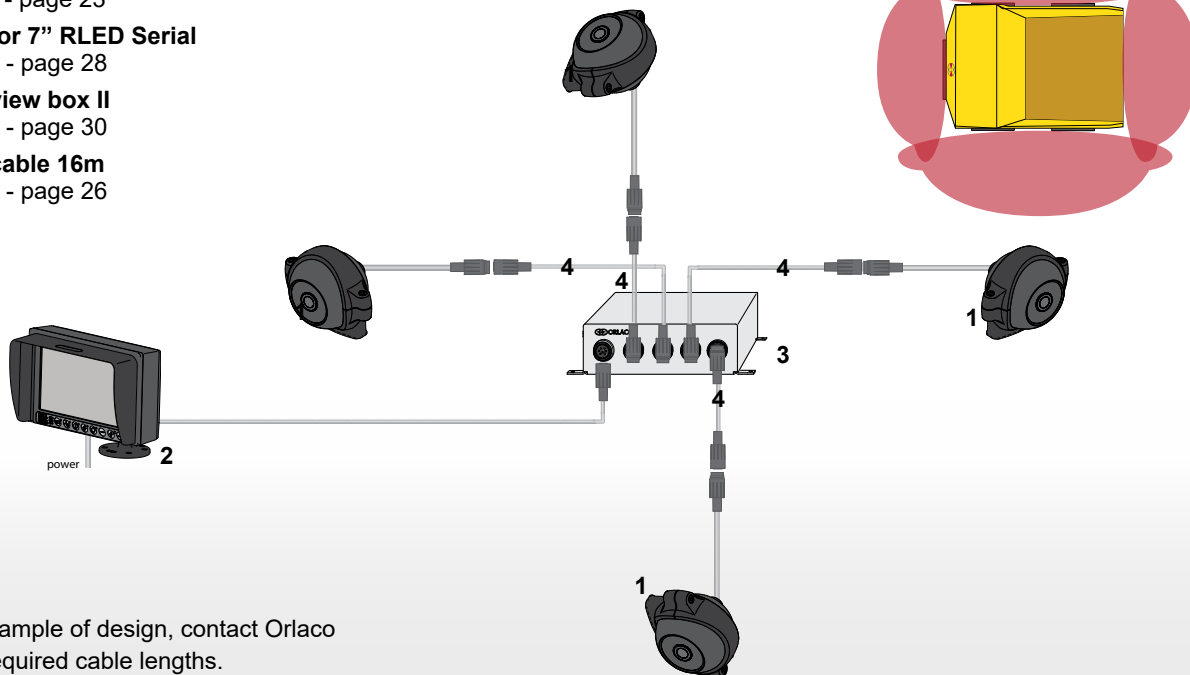

Note: Example of design, contact Orlaco for the required cable lengths.

Surround view



- Surround view can be applied on any type of vehicle.
- Increased visibility when manoeuvring in narrow spaces and busy areas.
- Images available: 180°, 270° or 360°.
- Surround view offers an overview of objects and people around a vehicle. They are always visible, thanks to overlapping camera images.
- Suitable for both 7" and 12" Orlaco monitors.
- Operating temperature between -40° and +85°C.
- A maximum of four different overviews can be programmed.
- No time-consuming calibration of cameras.
- Surround view can be designed and programmed in accordance with the customer's wishes.
- Contact Orlaco for more information and advice.

Three hundred and sixty degrees of visibility around a vehicle increases safety. The dimensions of a truck make it hard for a driver to get a complete overview of what is happening around his vehicle. Surround view gives him that overview. While manoeuvring, Surround view gives the driver maximum visibility on all sides of the truck via a single central monitor. The camera images overlap, allowing the driver to see every person and all objects around his vehicle. This greatly increases safety and efficiency. At street level, the surrounding area of the vehicle is clearly visible, even the corners. People and objects captured on the camera are shown in real size. This gives the driver an immediate, clear overview of the situation.



Forward manoeuvring



Reverse mode

Set **CornerEye**

1. Set HMOS camera with CornerEye bracket

0185610 - page 22

a. Camera HMOS 180°

b. CornerEye Bracket

2. Monitor HLED 10" MR1

0224000 - page 28

3. Monitor Bracket A pillar

0402610 - page 38

3. Digicoax cable

Make your choice - page 27

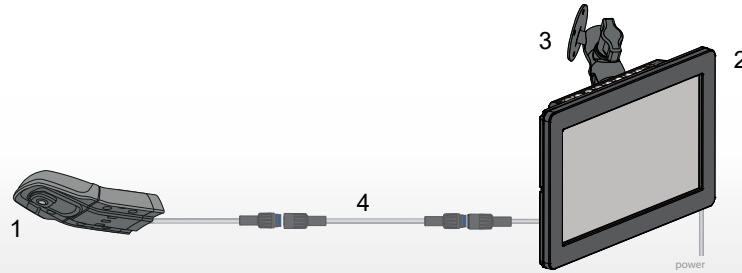

CornerEye delivers a real-time field of vision of 270°



Get excellent view on blind spots around heavy equipment with the revolutionary CornerEye camera monitor system. Ultimate digital technology and an effective application deliver a unique vision solution. The system has a wide angle lens that, combined with the latest technology, delivers a field of vision of 270°. An ideal solution for rear or side view on a vehicle.

- HD camera and 10" HD monitor
- 270° field of vision
- Real time: zero latency
- Shock and vibration proof
- Ruggedized design
- Designed to comply with automotive requirements
- Camera IP69K watertight
- Short mounting time
- Custom made bracket per brand on request

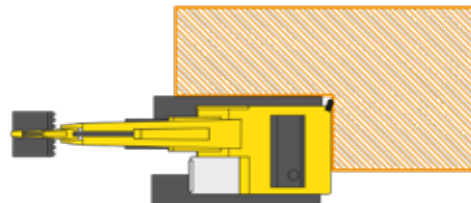

0185610 Set HMOS with bracket

- Including camera HMOS 180°

Or design your system yourself

- Step 1: Select your camera
- Step 2: Select your desired cable
- Step 3: Select your monitor
- Step 4: Select the required options

It is also possible to configure your system online on our website: www.orlaco.com

Whatever you select, the system can be easily installed and is plug-and-play.

Note: For two or more cameras a switcher, 4Cam RLED Monitor or MultiView Box and additional cables are required. Contact us for support.

The qualifications of our FAMOS Compact Cameras

- Next generation CMOS sensor
- Light sensitivity 0.05 lux
- Integrated *Safety ticker* to show that camera is running and active
- Optimized impact- and vibration-resistance
- Chemically hardened lens
- Automotive molding-filled housing, watertight IP69K according to DIN 40050-9
- Improved EMC-standards
- Operating temperature between -40°F to +185°F
- Heated lens glass, therefore no problems with condensation or frost
- Fixed lens
- IP68 dust- and waterproof according to IEC 60529
- The camera has a 0,5m cable including a watertight molded 4p male connector

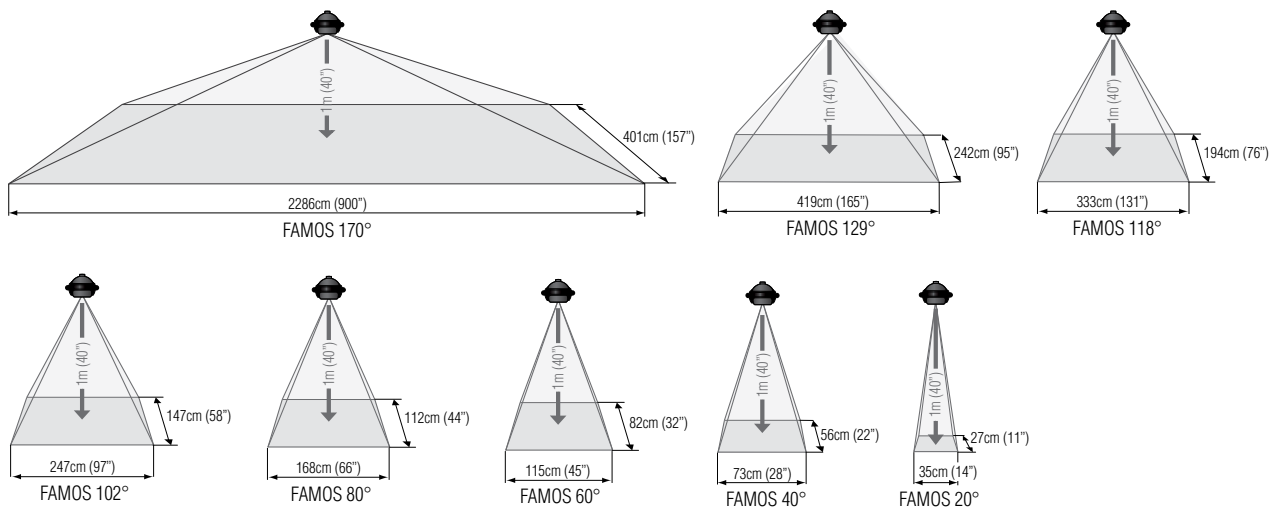

Cameras FAMOS

Type	Art. no. PAL	Art. no. NTSC
20°	0171060	0171160
40°	0171050	0171150
60°	0171040	0171140
80°	0171030	0171130
102°	0171020	0171120
102° MIRROR	0171220	0171240
118°	0171010	0171110
118° MIRROR	0171210	0171230
129°	0171000	0171100
170°	0171070	0171170





Camera FAMOS MIRROR SW1

Camera with mirrored image and guiding lines.

Type	Art. no. PAL	Art. no. NTSC
102° MIRROR	0171250	0171260



Cameras FAMOS IR LED

Day-night camera including 4 High Power Infrared LEDs 850nm. The IR LED's will be automatically activated. Based on the output of the CMOS sensor the IR illumination value will be set to ensure the best possible image.

Type	Art. no. PAL	Art. no. NTSC
80°	0171610	0171630
118°	0171600	0171620
118° MIRROR	0171900	0171910

- UV-transparent front cover

Cameras AMOS CPH

Robust camera for mounting on a vulnerable position.

Type	Art. no. PAL	Art. no. NTSC
51°, 0.66ft cable	0199710	0199740
51°, 1.97ft cable	0199700	0199730



For Zoom-, Thermal image- or Pan & Tilt cameras, please visit www.orlaco.com.

The additional qualifications of our High Definition Digital Cameras

- High resolution CMOS rolling shutter
- 1280 x 960 video image
- Excellent impact- and vibration-resistance
- Light sensitivity 0.1 lux
- Excellent EMC performance 100 V/m

Cameras HMOS

Compact, industrial high definition camera.

Type	Art. no.
30°	0185040
60°	0185030
90°	0185020
120°	0185010
180°	0185000

- With 0,5m cable including a digicoax waterproof molded 4p male connector
- Including camera bracket



Cameras EMOS

Low latency, high definition ethernet camera specifically designed for onboard computer systems.

Type	Art. no.
30°	0186040
60°	0186030
90°	0186020
120°	0186010
180°	0186000

- Image streaming in MJPEG or H.264
- Total system latency less than 100ms
- Communication according to ISO 17215 protocol



The advantages of Orlaco cables

- All cables are specially developed by Orlaco
- Special cables are available for various circumstances such as severe off-road conditions
- Resistant to oil and petrol
- Watertight cable connectors
- Operating temperature -40°F to +185°F

Multi cable standard

This standard cable can be used if no special requirements like mechanical protection or dynamic movement of the cable is needed.

Including 4p molded connectors:

0301960	3.3ft	(1 m)
0301870	6.6ft	(2 m)
0301890	9.8ft	(3 m)
0301880	16.4ft	(5 m)
0301910	24.6ft	(7,5 m)
0301930	26.2ft	(8 m)
0301950	29.5ft	(9 m)
0301900	36.1ft	(11 m)
0301920	52.5ft	(16 m)
0301940	68.9ft	(21 m)
0301990	131.2ft	(40 m)



Including 7p molded connectors:

0304420	1.6ft	(0,5 m)
0302820	3.3ft	(1 m)
0304260	6.6ft	(2 m)
0304410	19.7ft	(6 m)
0304610	36.1ft	(11 m)
0304620	52.5ft	(16 m)
0305030	68.9ft	(21 m)

Armored cable especially for severe off-road conditions

This cable offers good protection against severe conditions.

This is due to the additional internal galvanised braided steel wire armor. Attention: if cable is constantly moving as on a boom or hinged construction, please use the dynamic cable.

- For EMC 100V/m

Including 4p molded connectors:

0303342	4.9ft	(1.5 m)
0303352	9.8ft	(3m)
0303472	16.4ft	(5 m)
0303362	24.6ft	(7,5m)
0303372	29.5ft	(9 m)
0303482	36.1ft	(11 m)
0303492	52.5ft	(16 m)
0305021	65.6ft	(20 m)
0305011	91.9ft	(28 m)



Dynamic cable

Suitable for dynamic use, for instance for a Toolcam mounted on an arm or dipper stick, an excavator boom or in the between the moving part of an articulated dumptruck.

- Soft cover with small bend radius

Including 4p molded connectors:

0304371	1.6ft	(0,5 m)
0304281	3.3ft	(1 m)
0305341	11.5ft	(3,5 m)
0304341	16.4ft	(5 m)
0304381	19.7ft	(6 m)
0304391	26.2ft	(8 m)
0304431	29.5ft	(9 m)
0304441	32.8ft	(10 m)
0301811	36.1ft	(11 m)
0304451	39.4ft	(12 m)
0301731	45.9ft	(15 m)
0301831	65.6ft	(20 m)



Including 7p connectors:

0304460	9.8ft	(3 m)
0304470	13.1ft	(4 m)
0304480	16.4ft	(5 m)
0304490	26.2ft	(8 m)
0304560	29.5ft	(9 m)
0304570	32.8ft	(10 m)
0304580	36.1ft	(11 m)
0304590	55.8ft	(17 m)

Digicoax cable

Designed for use with HMOS cameras.

Including digicoax molded connectors:

0311000	3.3ft	(1 m)
0311010	6.6ft	(2 m)
0311020	9.8ft	(3 m)
0311030	16.4ft	(5 m)
0311040	24.6ft	(7,5 m)
0311050	26.2ft	(8 m)
0311060	29.5ft	(9 m)
0311070	36.1ft	(11 m)
0311080	52.5ft	(16 m)
0311090	68.9ft	(21 m)
0311100	131.2ft	(40 m)



The possibilities offered by Orlaco LED monitors

- Automotive TFT liquid crystal display module, LED backlight
- Operating temperature between -40°C to +85°C
- Impact and vibration resistance meet the stringent requirements
- Power protected against:
 - Induction voltages
 - Load dumps
 - Over- and undervoltage
- Mirror image setting
- Brightness automatically adjusts to

the ambient light

- Full On-Screen-Display (OSD) in 13 languages
- Watertight molded connectors
- Multiple view options for 12" monitor

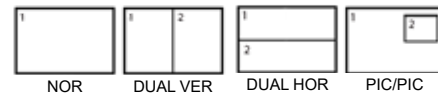

Monitor 7" RLED (Incl. 132mm bracket)



Monitor 12" RLED (Incl. 190mm bracket)



Monitor 10" HLED

Monitors RLED

- High resolution pixel WVGA 800xRGBx480
- Input Voltage 12...60V/DC +/-10%
- Option of a marker line per camera on the screen for the optimum determination of distance
- IP67 according to IEC 60529
- Integrated sun visor

Type	Video cable / connector	Power cable	Bracket	Art. no.
7"	6.6ft / 4p female	6.6ft open wired	5.2 inch	0208603
7" 4Cam	6.6ft Y-split / 4p female	6.6ft open wired	5.2 inch	0208612
7"	13.1ft / 4p female	13.1ft open wired	standard	0208681
7"	13.1ft / 4p female	13.1ft open wired	5.2 inch	0208672
7" Serial	19.7ft / 7p female	19.7ft open wired	5.2 inch	0208632
7" CAN SRD	19.7ft / 7p female	19.7ft open wired	5.2 inch	0208871
7" 4Cam CAN SRD	6.6ft Y-split / 4p-7p female	3.3ft open wired	5.2 inch	0209110
12"	13.1ft / 4p female	13.1ft open wired	7.5 inch	0411000
12" 4Cam	6.6ft Y-split / 4p female	6.6ft open wired	7.5 inch	0411040
12" 4Cam Serial	6.6ft Y-split / 4p female	6.6ft open wired	7.5 inch	0411170
12" Serial	19.7ft / 7p female	19.7ft open wired	7.5 inch	0411130
12" CAN	19.7ft / 7p female	19.7ft open wired	7.5 inch	0411200
12" CAN SRD	19.7ft / 7p female	19.7ft open wired	7.5 inch	0411300

4Cam Cable can be used to easily extend your system to display two cameras on one monitor or up to four cameras per monitor in combination with a Switcher. (see page 29)

CAN Two dedicated wires are suitable for CAN bus communication.

CAN SRD Specially designed for RadarEye systems. (see page 32-33)

Serial For serial connection (Zoom cameras, MultiView box).

Monitors HLED

- High resolution pixel WXGA 1280xRGBx800
- Input Voltage 12V / 24V/DC
- IP54 according to IEC 60529
- 1m multi cable (power) open wired, 1m multi cable (video) including 4p molded female coax connector

0224000 Monitor 10" HLED

Switchers

Input and power supply for three cameras and in combination with a Y-split cable: four cameras.

- Cameras can be switched over automatically or manually

0404040 Switcher UNI

- Waterproof IP54 according to IEC 60529
- 4p output for monitor

0404060 Switcher Serial

- Waterproof IP67 according to IEC 60529
- 7p output for monitor
- Only in combination with a Serial monitor
- Possibility to connect 1 serial Orlaco camera (AF Zoom)

0404080 Switcher UNI IP67

- Waterproof IP67 according to IEC 60529
- 4p output for monitor



0404300 Switcher 4Cam (for third party monitor)

This video switcher for third party monitors has 4 video inputs and 1 video output

- Connect up to 4 cameras (PAL or NTSC) to a third party monitor
- Including 12.6ft power cable
- Please contact Orlogo for the appropriate cables



Power supply

0004601 Power supply 9-36V

- Maximum cable length 656ft
- Power input 9-36V/DC
- Power output 12V/DC



Video distributor

0407001 Orlogo video distributor

For connecting a second and third Orlogo monitor.

- 7 - 32 V/DC
- Cables and connectors are not included





Orlaco IP SmartView

0060310 Licence Smartview software

View and control of cameras over TCP/IP or a local computer network.

- Support H.264 digital video codec
- Multiple display settings (full, split, quadviews, 8 and 16 cams on 1 screen)
- Individual camera presets and master presets for controlling multiple PTZ simultaneously
- Sequential camera switcher
- Motion detection
- Supplied on USB memory stick
- Please contact Orlaco for further information

Multiview

- Stainless steel housing
- Serial Orlaco Monitor needed

0405100 MultiView box II

- 4 camera inputs (4x Compact Camera)

0405110 MultiView box II

- 4 camera inputs (3x Compact Camera 1x AF-Zoom Camera)



0405300 Quad Box II 4Cam

- 4 camera inputs (4x Compact Camera)
- Stainless steel housing
- Serial Orlaco Monitor needed
- Including powercord

Preset view options for channel 1-4:



Default channel 5:

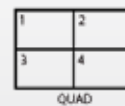

Digital video recorder

0000300 DVR one channel

Digital video recorder with one camera input and one video output

- Can be used with a compact camera (4p) or serial camera (7p)
- Video loop function
- 9-30V/DC
- Automatic timestamp
- Including 32GB SDHC-card for max 72 hours of storage and SD-card reader



0000250 DVR Multi view

Digital video recorder with four camera inputs and one video output with multiview options.

- Suitable for compact cameras (4p)
- Including 128GB 80 MB/s SDXC-card for max 72 hours of storage



0000260 DVR 4Cam

Digital video recorder with four camera inputs and four video outputs.

- Suitable for compact cameras (4p)
- Including 128GB 80 MB/s SDXC-card for max 72 hours of storage



Push button

8975760 Push button yellow

For manually switching between cameras.



Joystick

0506500 Joystick

- Built-in, IP40
- Operating temperature between -22°F to +167°F
- Telemanique



RadarEye unites visibility and active detection



Orlaco has developed this radar unit in addition to the camera- monitor systems. By combining the vision solution with an active signaling system, RadarEye offers additional safety and efficiency.

RadarEye is an integrated active view system designed to detect and see objects in zones obscured from the driver's view. The radar system detects stationary as well as moving objects in a designated coverage area. With this view system the driver is actively warned with audible tones that increase in rate as objects come closer. When an object is detected it can be seen on the monitor and the driver can respond immediately. This prevents damage to the drivers truck and any other equipment he may reverse into. The radar units have a rugged design, are shockproof, waterproof and is not influenced by the environment, such as snow, rain, mud and or temperature changes.



[Check our demo RadarEye videos on the Orlaco YouTube channel.](#)

- RadarEye can be used on various machines
- RadarEye is capable of visualizing the radar-zones on the display. As soon as an object enters the zone it will activate colored dots (default setting) or a transparent visualization (standard/custom preset settings) to make the driver aware of the potential danger
- 6.6...65.6ft detection area, divided in 5 equally sized segments
- Separation distance: 3.3 -13.1ft (configurable)
- Antenna beam horizontal: 70°(typ.), vertical: 11°(typ.)
- Operating temperature between -40°F to +185°F
- Obstacle reaction delay 50ms
- Can be connected to an Orlaco monitor or third party monitor with PAL/NTSC input
- RadarEye can be extended with multiple sensor and camera units for all around detection and visibility
- Please contact Orlaco for advice and installation

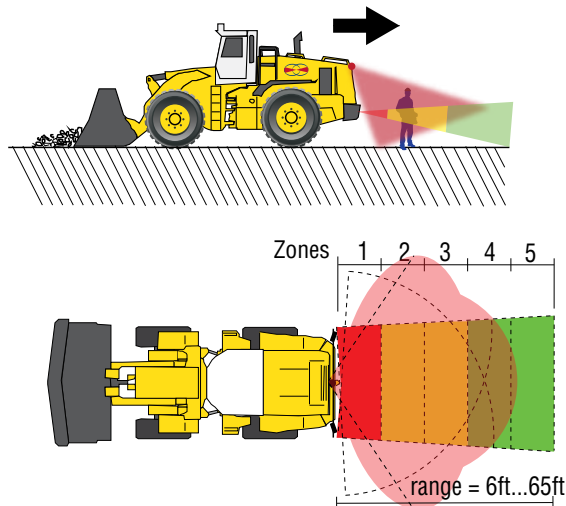

RadarEye Sets

0403120 Set SRD Corner Rear

Active Rearview system for corner mounting.

- Including SRD sensors, brackets and terminator
- Interface Box CAN/SRD/camera is required (0256010 or 0504820)
- Cables, camera and monitor CAN SRD are not included

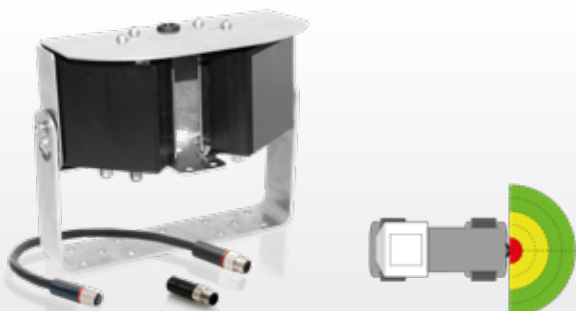

0403100 Set SRD Center Rear

Active Rearview system for center mounting.

- Including SRD sensors, bracket, cable master-slave (0301080) and terminator
- Interface Box CAN/SRD/camera is required (0256010 or 0504820)
- Cables, camera and monitor CAN SRD are not included

RadarEye Interface boxes

0256010 Interface Box CAN/SRD/camera

The Interface Box is designed to connect SRD sensors to camera and CAN SRD monitor.

0504820 Interface Box with ext. speaker CAN/SRD/camera

The Interface Box is designed to connect SRD sensors to a camera, CAN SRD monitor and external speaker.

- Set consists of: External speaker and Interface Box
- Sound pressure speaker: 85dB (+/-3dB) distance 1m



RadarEye Interface box for existing monitors

0404700 SRD Interface Box with ext. speaker

The Interface Box is designed to connect the RadarEye components to a non-radar third party monitor (PAL/NTSC) or existing standard camera system.

- Set consists of: Interface box, external speaker, adapterplug and open wired multicable with 8p connector.
- Sound pressure speaker: 85dB (+/-3dB) distance 1m



RadarEye Cables

Cable M12 Green

Connection cable between Interface box and master SRD sensor or connection cable between slave SRD sensor and next SRD sensor.

0301051	5m	0301061	10m
0301071	15m	0301121	20m
0301131	25m	0301141	30m

Cable M12 Master-Slave Red

Connection cable between master SRD sensor and slave SRD sensor.

0301081	0,25m	0301021	1m
0301031	4m	0301041	8m
0301091	16m		



RadarEye Brackets

0401330 Bracket SRD Sensor Corner Rear

Mounting bracket for SRD Sensor for corner mounting

- Stainless steel
- SRD sensor not included

0401320 Bracket SRD Sensor Center Rear

Mounting bracket for SRD Sensor for center mounting

- Stainless steel
- SRD sensors not included

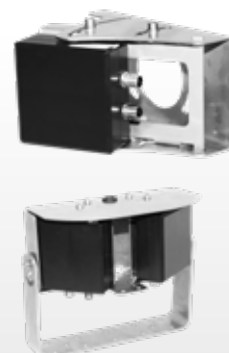



Spectrum Scanner wireless video transmitter & receiver

- Including powercable and two adjustable brackets for transmitter and receiver
- 8 video channels
- Full On Screen Display (OSD) functionality for system settings
- Please contact your dealer for further advice

0004061 RoundMax 150

- Omnidirectional antenna with horizontal orientation
- Maximum range 492ft (dependent on surroundings)



0004091 LineMax 300

- Directional antenna with vertical orientation
- Maximum range 984ft (dependent on surroundings)

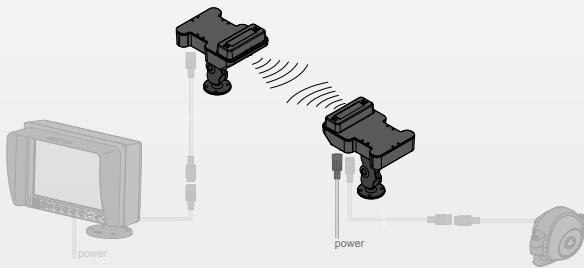
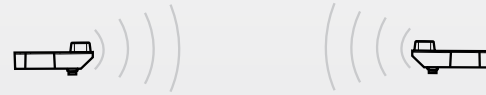

Split cable (6.6ft)

0303781 Y-Split cable UNI RLED

- With two 4p female connectors (video) and open wire cable (power)
- For connections 2 to 4 cameras (with Switcher)



Cable per metre (without connectors)

- 1220110 Multicable 1x coax, 2x power, 1x data
- 1220170 Multicable 1x coax, 5x wires
- 1220280 Multicable armored 1x coax, 5x wires
- 1220350 Multicable 2x coax, 5x wire
- 1220600 Dynamic cable 1x coax, 5x wire
- 1220900 Power cable 7x wire
- 1222000 Coax cable 75 OHM RG59

Any required connectors can be ordered separately. (page 35)

Adapter cables

- 0304000 Interface cable 4p female - 4p female
- 0304050 Interface cable 4p male - 4p male
- 0304210 Interface cable 4p female - 7p male
- 0304220 Interface cable 4p male - 7p female
- 0303860 Interface cable 4p female - BNC
- 0303770 Adapter cable 4p female - Cinch/RCA
(if OEM monitor is used)
- 0304090 Adapter cable HMI monitor Fendt



Connectors

- 1310841 Connector 4p female Gold
 - Recommended for multicable
- 1312001 Connector 4p male Gold
 - Recommended for multicable
- 1310850 Connector 4p female PG9 Gold
 - Recommended for dynamic and armored cable
- 1312050 Connector 4p male PG9 Gold
 - Recommended for dynamic and armored cable



Bulkhead Connectors

- Suitable for lead-through on bodywork
- 0357011 Bulkhead connector 4p
- 0357051 Bulkhead connector 7p





Mounting means

0402310 Aerodynamic cover + nozzle

Specially designed for the Compact Camera. The nozzle allows high pressure cleaning of the camera lens.

- Hose and water tank are not included
- Stainless steel



0402320 Protective cover

Cover specially designed for the Compact Camera.

- Stainless steel housing



Camera extension brackets

Specially designed for the Compact Camera. Matches the hole pattern of the Compact Camera bracket.

- Stainless steel

0402250 Camera extension 6.1 inch



0402270 Camera extension 9.8 inch



0403310 Shock-absorbers for Compact Camera

In situations where shock absorption plays a major role, we recommend that the specially developed shock absorbers are used when installing the Compact Camera.

0402450 Camera Housing Dome
Ceiling mount for Compact Camera.

- Aluminium housing
- Including mounting hardware
- Compact Camera is not included



0401270 Camera bracket
Compact bracket specially designed for the Compact Camera.

- Cap can be resprayed in the color of the vehicle
- Including mounting kit
- Compact Camera are not included



0403400 Compact Camera magnet bracket
For quick mounting of Compact Camera on steel profiles.



8400610 Compact Camera bracket
Assembly set for Compact Camera.



2015750 Ball joint with connection plate



2015710 Ball joint 3/8" thread





2015900 Ball joint double



2015700 Adjustable mounting bracket 3/8" UNC
• Length 5.1 inch

2015500 Adjustable mounting bracket
• Length 5.2 inch

2015600 Adjustable mounting bracket
• Length 7.5 inch



2015510 Arm component 3.5 inch

2015800 Arm component 5.7 inch



0402610 Monitor Bracket A Pillar
• Suitable for Monitor 10" HLED

ISO Certifications

All Orlaco products are manufactured according to the latest *Quality Management System Standards*:

ISO/TS 16949 : 2009

ISO 9001 : 2008

Additionally, all Orlaco products are manufactured according to the latest *Environmental Management System Standard*:

ISO 14001 : 2004



Type-Approval Certifications

Regulations 10 and 46 are used to determine the Type-Approval for **EMC** and **Indirect Vision** (Mirror Directive). **R46** describes mirror specifications for truck compliancy. Orlaco Frontview systems meet all these requirements. **R10** describes the **EMC** behavior of the Orlaco Camera and Monitor systems.



TÜV Automotive Certifications

The *European Agreement concerning the International Carriage of Dangerous Goods by Road (ADR)* demands additional equipment. Orlaco Camera and Monitor systems and connection cables comply with these regulations.

Compliance

Our Camera and Monitor systems are produced entirely in line with the **CE-marking** and the most recent applicable directives and product standards (e.g. **EMC**, **FCC**, **Machinery**, **R&TTE**). Orlaco products are compliant with **RoHS** and **REACH**.





**Orlaco Inc
Headquarters North America**

- 33 Confederate Avenue
Jasper, GA 30143
United States
- Phone +1 706 301 9227
- infoNA@orlaco.com
- www.orlaco.com

It is Orlaco's viewpoint that optimal vision around every vehicle and vessel should be the norm. It provides safety, comfort, efficiency and less damage. *Vision is our mission®*. A revealing mission. We develop professional vision solutions for every situation:



Orlaco is not responsible or liable for any errors, inaccuracies or omissions or from the results obtained from the use of this information.

No part of this publication may be copied, reproduced or distributed in any form without express written permission from Orlaco.
©2019 Orlaco

Dealer:

[Check our website for all our brochures \(pdf\).](#)